

OPERATION & PARTS MANUAL



SideWinder

MODEL HS62A CUT-OFF SAW

Revision #0 (03/20/06)

To find the latest revision of this
publication, visit our website at:
www.multiquip.com



THIS MANUAL MUST ACCOMPANY THE EQUIPMENT AT ALL TIMES.



WARNING



CALIFORNIA — Proposition 65 Warning

Engine exhaust and some of its constituents, and some dust created by power sanding, sawing, grinding, drilling and other construction activities contains chemicals known to the State of California to cause cancer, birth defects and other reproductive harm. Some examples of these chemicals are:

- Lead from lead-based paints.
- Crystalline silica from bricks.
- Cement and other masonry products.
- Arsenic and chromium from chemically treated lumber.

Your risk from these exposures varies, depending on how often you do this type of work. To reduce your exposure to these chemicals: **ALWAYS** work in a well ventilated area, and work with approved safety equipment, such as dust masks that are specially designed to filter out microscopic particles.

HS62A CUT-OFF SAW — TABLE OF CONTENTS

MULTIQUIP — HS62A CUT-OFF SAW

Proposition 65 Warning	2
Table Of Contents	4
Parts Ordering Procedures	5
Safety Message Alert Symbols	6-7
Rules For Safe Operation	8-11
Specifications (Saw/Engine)	12
Decal Placement	13
Controls & Components	14-15
Blade Installation Instructions	16
Water Kit Installation Instructions	17
Blades	18
Initial Start-Up/Operation	19-20
Maintenance	21-25
Troubleshooting (Blade)	26
Troubleshooting (Engine)	27-28
Filter Kits	29
Explanation of Codes in Remarks Column	30
Suggested Spare Parts	31

Carburetor Mounting Assembly	56-57
Carburetor Assembly	58-59
Crankshaft and Piston Assembly	60-61
Water Kit Assembly	62-63
Tools	64-65
Recommended Diamond Blades	66
Terms and Conditions of Sale — Parts	67

COMPONENT DRAWINGS

Muffler Assembly	32-33
Recoil Start Assembly	34-35
Crankcase Assembly	36-37
V-belt Cover (Clutch Side) Assembly	38-39
V-Belt Cover (Pulley) Blade Guard Assembly	40-41
Fuel Tank Assembly	42-43
Lifting Handle and Roller Assembly	44-45
Throttle Linkage Assembly	46-47
Flywheel Cover Assembly	48-49
Flywheel Assembly	50-51
Ignition Assembly	52-53
Air Filter Assembly	54-55

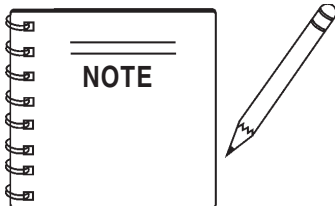

Specifications and part numbers are subject to change without notice.

www.multiquip.com

**Ordering parts has never been easier!
Choose from three easy options:**



Order via Internet (Dealers Only):

Order parts on-line using Multiquip's SmartEquip website!

- View Parts Diagrams
- Order Parts
- Print Specification Information



If you have an MQ Account, to obtain a Username and Password, E-mail us at: **parts@multiquip.com**.

To obtain an MQ Account, contact your District Sales Manager for more information.

Goto www.multiquip.com and click on **Order Parts** to log in and save!

Use the **internet** and qualify for a **5% Discount** on *Standard orders* for all orders which include complete part numbers.*

Note: Discounts Are Subject To Change



Order via Fax (Dealers Only):

All customers are welcome to order parts via Fax.

Domestic (US) Customers dial:
1-800-6-PARTS-7 (800-672-7877)

Fax your order in and qualify for a **3% Discount** on *Standard orders* for all orders which include complete part numbers.*

Note: Discounts Are Subject To Change



Order via Phone: Domestic (US) Dealers Call:
1-800-427-1244

Non-Dealer Customers:

Contact your local Multiquip Dealer for parts or call 800-427-1244 for help in locating a dealer near you.



International Customers should contact their local Multiquip Representatives for Parts Ordering information.

When ordering parts, please supply:

- | | |
|--|--|
| <ul style="list-style-type: none"> <input type="checkbox"/> Dealer Account Number <input type="checkbox"/> Dealer Name and Address <input type="checkbox"/> Shipping Address (if different than billing address) <input type="checkbox"/> Return Fax Number <input type="checkbox"/> Applicable Model Number <input type="checkbox"/> Quantity, Part Number and Description of Each Part | <ul style="list-style-type: none"> <input type="checkbox"/> Specify Preferred Method of Shipment: <ul style="list-style-type: none"> <input checked="" type="checkbox"/> Fed Ex/UPS <input checked="" type="checkbox"/> Priority One <input checked="" type="checkbox"/> Ground <input checked="" type="checkbox"/> Next Day <input checked="" type="checkbox"/> Second/Third Day <input checked="" type="checkbox"/> DHL <input checked="" type="checkbox"/> Truck |
|--|--|

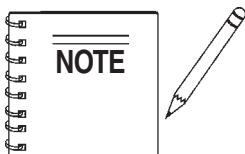

Unless otherwise indicated by customer, all orders are treated as *Standard Orders* and will ship within 24 hours. We will make every effort to ship *Air Shipments* the same day the order is received, if received prior to 2PM PST. *Stock Orders* must be noted on fax or web order form.

WE ACCEPT ALL MAJOR CREDIT CARDS!



HS62A CUT-OFF SAW — SAFETY MESSAGE ALERT SYMBOLS

FOR YOUR SAFETY AND THE SAFETY OF OTHERS!

Safety precautions should be followed at all times when operating this equipment. Failure to read and understand the Safety Messages and Operating Instructions could result in injury to yourself and others.

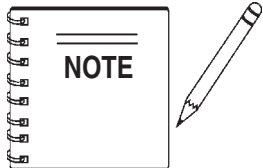

This Owner's Manual has been developed to provide complete instructions for the safe and efficient operation of the MULTIQUIP MODEL HS62A **CUT-OFF SAW**. For engine maintenance information, please refer

to the maintenance section of this manual for data relative to its safe operation.

Before using this SAW, ensure that the operating individual has read and understands all instructions in this manual.

SAFETY MESSAGE ALERT SYMBOLS

The three (3) Safety Messages shown below will inform you about potential hazards that could injure you or others. The Safety Messages specifically address the level of exposure to the operator, and are preceded by one of three words: **DANGER**, **WARNING**, or **CAUTION**.

DANGER

You **WILL** be **KILLED** or **SERIOUSLY** injured if you **DO NOT** follow directions.

WARNING

You **CAN** be **KILLED** or **SERIOUSLY** injured if you **DO NOT** follow directions.

CAUTION

You **CAN** be **INJURED** if you **DO NOT** follow directions.

HAZARD SYMBOLS



Lethal Exhaust Gases



Engine exhaust gases contain poisonous carbon monoxide. This gas is colorless and odorless, and can cause death if inhaled. **NEVER** operate this equipment in a confined area or enclosed structure that does not provide ample free flow air.



Explosive Fuel



Gasoline is extremely flammable, and its vapors can cause an explosion if ignited. **DO NOT** start the engine near spilled fuel or combustible fluids. **DO NOT** fill the fuel tank while the engine is running or hot. **DO NOT** overfill tank, since spilled fuel could ignite if it comes into contact with hot engine parts or sparks from the ignition system. Store fuel in approved containers, in well-ventilated areas and away from sparks and flames. **NEVER** use fuel as a cleaning agent.



Burn Hazards



Engine components can generate extreme heat. To prevent burns, **DO NOT** touch these areas while the engine is running or immediately after operations. **NEVER** operate the engine with heat shields or heat guards removed.



Rotating Parts



NEVER operate equipment with covers, or guards removed. Keep **fingers, hands, hair** and **clothing** away from all moving parts to prevent injury.

HS62A CUT-OFF SAW — SAFETY MESSAGE ALERT SYMBOLS



Accidental Starting



OFF **ALWAYS** place the engine ON/OFF switch in the **OFF** position, when the saw is not in use.



Respiratory Hazard



ALWAYS wear approved respiratory protection.



Over Speed Conditions



NEVER tamper with the factory settings of the engine governor or settings. Personal injury and damage to the engine or equipment can result if operating in speed ranges above maximum allowable.



Sight and Hearing hazard

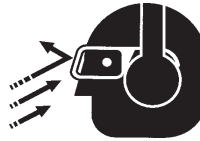

ALWAYS wear approved eye and hearing protection.



Guards and Covers In Place

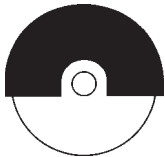

NEVER operate the saw without blade guards and covers in place. Adhere to safety guidelines ANSI, OSHA, or other applicable local regulations.



Equipment Damage Messages

Other important messages are provided throughout this manual to help prevent damage to your concrete saw, other property, or the surrounding environment.



Rotating Blade

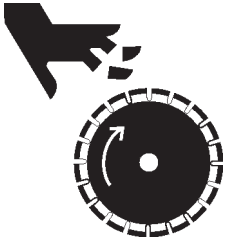

Rotating blade can cut and crush. Keep hands and feet clear.

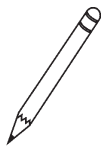
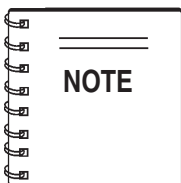

This **concrete/asphalt saw**, other property, or the surrounding environment could be damaged if you do not follow instructions.

HS62A CUT-OFF SAW — RULES FOR SAFE OPERATION

WARNING - Read This Manual

Failure to follow instructions in this manual may lead to **Serious Injury** or even **Death**. This equipment is to be operated by trained and qualified personnel only! This equipment is for industrial use only.

The following safety guidelines should always be used when operating the Multiquip HS62A Cut-off Saw.

SAFETY

- **DO NOT** operate or service this equipment before reading this entire manual.



- This equipment should not be operated by persons under 18 years of age.
- **NEVER** operate the saw without proper protective clothing, shatterproof glasses, steel-toed boots and other protective devices required by the job.



- **NEVER** operate this equipment when not feeling well due to fatigue, illness or taking medicine.



- **NEVER** operate the saw under the influence of drugs or alcohol.



- **NEVER** use accessories or attachments, which are not recommended by Multiquip for this equipment. Damage to the equipment and/or injury to user may result.
- Manufacturer does not assume responsibility for any accident due to equipment modifications. Unauthorized equipment modification will void all warranties.
- Whenever necessary, replace nameplate, operation and safety decals when they become difficult read.
- **ALWAYS** check the saw for loosened hardware such as nuts and bolts before starting.

- **NEVER** touch the hot exhaust manifold, muffler or cylinder. Allow these parts to cool before servicing the saw.

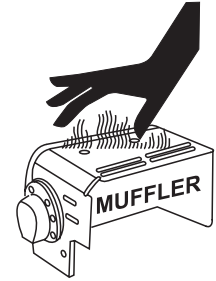

- **High Temperatures** – Allow the engine to cool before adding fuel or performing service and maintenance functions. Contact with **hot!** components can cause serious burns.

- The engine of this saw requires an adequate free flow of cooling air. **NEVER** operate the saw in any enclosed or narrow area where free flow of the air is restricted. If the air flow is restricted it will cause serious damage to the saw's engine and may cause injury to people. Remember the saw's engine gives off **DEADLY** carbon monoxide gas.

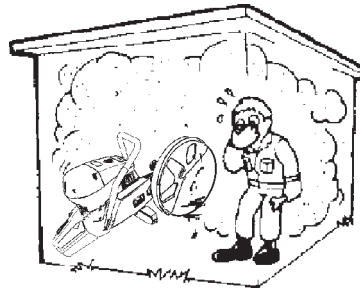

- **ALWAYS** refuel in a well-ventilated area, away from sparks and open flames.

- **ALWAYS** use extreme caution when working with **flammable** liquids. When refueling, **STOP** the engine and allow it to cool.

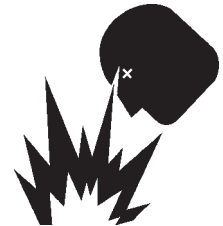

- **NEVER smoke** around or near the saw. Fire or explosion could result from **fuel vapors**, or if fuel is spilled on a **hot!** engine.



- **NEVER** operate the saw in an explosive atmosphere where fumes are present or near combustible materials. An explosion or fire could result causing severe **bodily harm or even death**.

- **ALWAYS** move the saw at least 10 feet away from the fueling point before starting the engine and make sure the gas cap on the saw and the fuel can are properly tightened.

- Topping-off to filler port is dangerous, as it tends to spill fuel.
- **NEVER** use fuel as a cleaning agent.

HS62A CUT-OFF SAW — RULES FOR SAFE OPERATION

General Safety

- **ALWAYS** read, understand, and follow procedures in Operator's Manual before attempting to operate this equipment.



- **ALWAYS** wear proper respiratory (mask), hearing and eye protection equipment when operating the saw.



- **ALWAYS** be sure the operator is familiar with proper safety precautions and operating techniques before using the saw.
- **ALWAYS** inspect the blade, flanges and shafts for damage before installing the blade.
- **ALWAYS** use high-speed, reinforced, abrasive blades - 1/8" (3.17 mm) thick (minimum) or high-speed, diamond blades specifically rated with a maximum operating speed of at least 5,400 RPM on 14" (350 mm) or 6,200 RPM on 12" (300 mm).
- **ALWAYS** use high-speed reinforced, abrasive blades or high-speed, diamond blades marked with a 1" (25.4 mm) hole for a 1" (25.4 mm) flange, or a 20 mm hole for a 20 mm flange.
- **ALWAYS** use abrasive blades or high-speed diamond blades marked for use with gasoline-powered, hand-held, portable, abrasive cutting-off saws.
- **ALWAYS** read all safety materials and instructions that accompany any blade used with this saw.
- **ALWAYS** inspect each blade carefully before using it. If there are any signs of damage or unusual wear, **DO NOT USE THE BLADE.**
- **ALWAYS** verify the blade arbor hole matches the saw's spindle before mounting the blade.
- **ALWAYS** mount the blade **solidly** and **firmly**. Wrench tighten the arbor nut.
- **ALWAYS** make sure the blade and flanges are clean and free of dirt and debris before mounting the blade on the saw.
- **ALWAYS** use the correct blade for the type of work being done. Check with blade manufacturer if you do not know if blade is correct for desired application.

- **ALWAYS** hold the saw with both hands when the engine is running. Use a firm grip with thumbs and fingers encircling the handles.
- **ALWAYS** keep all parts of the body away from the cutting-off blades when the engine is running.
- **ALWAYS** keep the handles dry, clean and free of oil or fuel.
- **ALWAYS** carry the saw with the engine stopped and the muffler away from the body.
- **ALWAYS** instruct bystanders on where to stand while the saw is in operation.
- **ALWAYS** clear the work area of unnecessary people.
- **NEVER** allow anyone to stand in front of or behind the blade while the engine is running.
- **ALWAYS** make sure the blade is not contacting any objects before starting the engine.
- **ALWAYS** check for buried electrical cables before sawing. If unsure, contact the local utilities.
- **ALWAYS** have all service and maintenance performed by competent trained service personnel.
- **ALWAYS** clean the saw after each day's use.
- **ALWAYS** have a copy of this manual at the job site.
- **ALWAYS** stop the engine before servicing, adding fuel and oil.
- **ALWAYS** service air cleaner frequently to prevent carburetor malfunction.
- **ALWAYS** keep clear of **rotating** or **moving parts** while the saw is in operation.
- **ALWAYS** maintain this saw in a **safe** operating condition at **all times**.
- **ALWAYS** keep any inexperienced and unauthorized people away from the saw at all times.
- **ALWAYS** store saw properly when it is not being used. Equipment should be stored in a clean, dry location out of the reach of children.

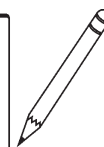
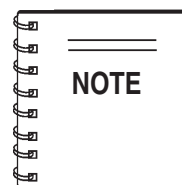

This saw is designed for certain applications only. **DO NOT** use or modify this saw for any application other than for which it was designed.

HS62A CUT-OFF SAW — RULES FOR SAFE OPERATION

- **NEVER** leave the machine *unattended* while running.
- **NEVER** run the engine without the air filter. Severe engine damage could occur.
- **NEVER** wear jewelry or loose fitting clothing that may snag on the controls or moving parts, this can cause a serious injury.
- **NEVER** operate this saw without the blade guard, or other protective guards in place.
- **NEVER** stand behind or in front of the blade path while the engine is running.
- **NEVER** use abrasive blades that are less than 1/8" (3.17 mm) thick.
- **NEVER** exceed maximum blade speed shown for each blade size. Excessive speed could result in blade breakage.
- **NEVER** use a damaged saw or blades.
- **NEVER** try to stop a moving blade with your hand.
- **NEVER** use an abrasive blade that has been dropped.
- **NEVER** use carbide-tipped or toothed type blades of any kind.
- **NEVER** use segmented diamond blades unless they are specifically designed for high-speed, hand-held saws.
- **NEVER** place 1 inch (25.4 mm) arbor hole blades on 20 mm flanges.
- **NEVER** use the side of a cutting-off blade as a grinder.
- **NEVER** cock, jam or wedge the blade in the cut.
- **NEVER** operate the saw if the blade does not stop rotating when the throttle trigger is released.
- **NEVER** start cutting until you have a clear work area and secure footing.
- **NEVER** allow other persons to be near the saw when starting, refueling, or when the saw is operating.
- **NEVER** allow bystanders or animals in the work area while using a cutting-off machine.
- **NEVER** touch a dry cutting diamond blade immediately after use. These blades require several minutes to cool after each cut.
- **NEVER** use damaged or worn blade flanges. Discard any damage or worn saw parts.
- **NEVER** allow blade exposure from the guard to be more than 180 degrees.
- **NEVER** operate this saw without both hands on the handles.

Diamond Blade Safety

- Use appropriate steel centered diamond blades manufactured for use on concrete saws.



- **ALWAYS** inspect diamond blades before each use. The blade should exhibit no cracks, dings, or flaws in the steel centered core and/or rim. Center (arbor) hole must be undamaged and true.
- Examine blade flanges for damage, excessive wear and cleanliness before mounting blade. Blade should fit snugly on the shaft and against the inside/outside blade flanges.
- Ensure the blade is marked with an operating speed greater than the blade shaft speed of the saw.
- Only cut the material that is specified by the diamond blade. Read the specifications of the diamond blade to ensure the proper tool has been matched to the material being cut.
- **ALWAYS** keep blade guards in place. Exposure of the diamond blade must not exceed 180 degrees.
- Ensure that the diamond blade does not come into contact with the ground or surface during transportation. **DO NOT** drop the diamond blade on ground or surface.
- The engine governor is designed to permit maximum engine speed in a no-load condition. Speeds that exceed this limit may cause the diamond blade to exceed the maximum safe allowable speed.
- Ensure that the blade is mounted correctly for proper operation.



Saw Transportation Safety

- **NEVER** transport the saw with the blade mounted.
- **ALWAYS** use caution when *lifting* and *transporting* this saw.
- **ALWAYS** tie-down the saw when transporting.
- **ALWAYS** use caution and follow the instructions when loading and unloading the saw.

HS62A CUT-OFF SAW — RULES FOR SAFE OPERATION

EMERGENCIES

- **ALWAYS** know the location of the nearest **fire extinguisher**.



- **ALWAYS** know the location of the nearest **first aid kit**.



- In emergencies **always** know the location of the nearest phone or **keep a phone on the job site**. Also know the phone numbers of the nearest **ambulance**, **doctor**, and **fire department**. This information will be invaluable in the case of an emergency.



HS62A CUT-OFF SAW — SPECIFICATIONS

Table 1. HS62A Cut-off Saw Specifications

Dimension (Shipping) LxWxH	50 x 33 x18 in. (1270 x 838 x 457 mm)
Weight	22.9 lbs. (10.4 kg)
Blade Size	14 in. (356 mm)
Maximum Cut Depth	5 in. (127 mm)
Arbor Size	1 in. (20 mm)
Cutting Arm	Reversible

Table 2. HS62A Power Source Specifications

Engine Type	Two-Stroke, Single Cylinder, Air cooled	
Displacement	3.86 cu. in (63.3 cc.)	
Maximum Spindle Speed	5,100 RPM	
Engine Speed	10,000 RPM	
Idle Speed	2,500 RPM	
Dimensions (LxWxH)	29.13 x 8.27 x 15.75 in. (740 x 210 x 400 mm)	
Fuel Tank Capacity	.17 Gallons. (.65 Liters)	
Fuel/Oil Mix Ratio	See Figure 13, Page 19	
Starting Method	Recoil Start	
Ignition	Type	Electronic Speed Controlled
	Gap	.014 in. (.35 mm)
Spark Plugs	Manufacturer	Champion/NGK
	Type	RCJ7Y/BPR6A
	Gap	.020 (0.5 mm)
Carburetor	Manufacturer	Walbro
	Model	HD207
	Type	Diaphragm/Semi-Fixed Jet

HS62A CUT-OFF SAW — DECAL PLACEMENT

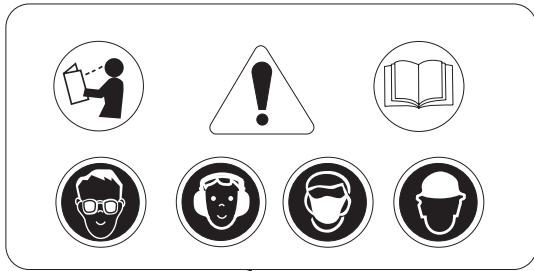

P/N DCL 230

Machine Operation And Safety Decals

The HS62A CUT-OFF SAW is equipped with a number of operation and safety decals (Figure 1). Should any of these decals become unreadable, replacements can be obtained from your dealer.

R.P.M.
5100

P/N DCL 231

**Primary Filter Here
Clean and Re-oil Daily**

**Secondary filters below
Replace as needed**

P/N DCL 232

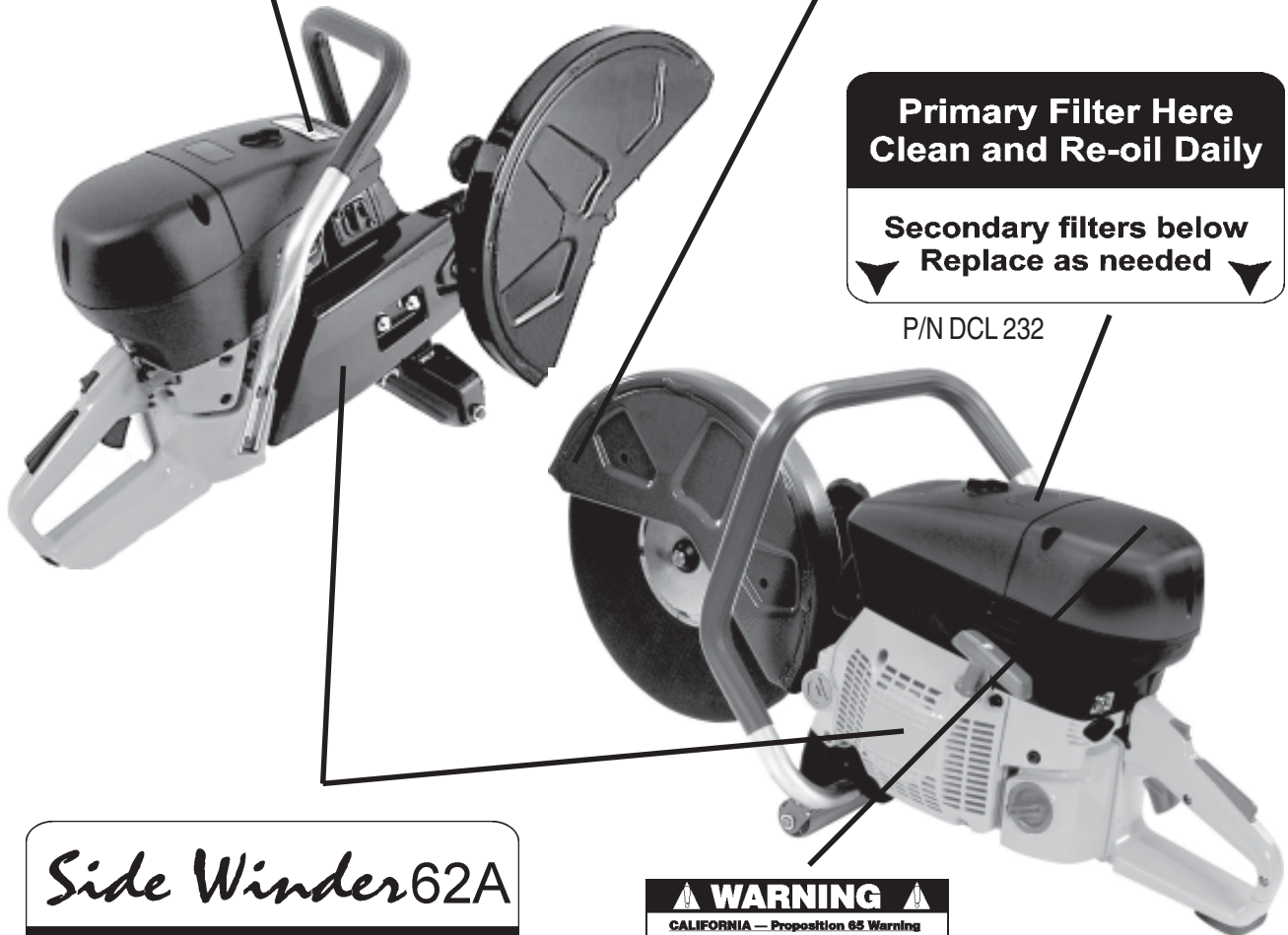

Side Winder 62A
MULTIQUIP

P/N DCL 233A

WARNING

CALIFORNIA — Proposition 65 Warning

Engine exhaust and some of its constituents, and some dust created by power sanding, sawing, grinding, drilling and other construction activities contains chemicals known to the State of California to cause cancer, birth defects and other reproductive harm. Some examples of these chemicals are:

- Lead from lead-based paints.
- Crystalline silica from bricks.
- Cement and other masonry products.
- Arsenic and chromium from chemically treated lumber.

Your risk from these exposures varies, depending on how often you do this type of work. To reduce your exposure to these chemicals: **ALWAYS** work in a well ventilated area, and work with approved safety equipment, such as dust masks that are specially designed to filter out microscopic particles.

P/N DCL 161

Figure 1. Safety Decals

HS62A CUT-OFF SAW — CONTROLS & COMPONENTS

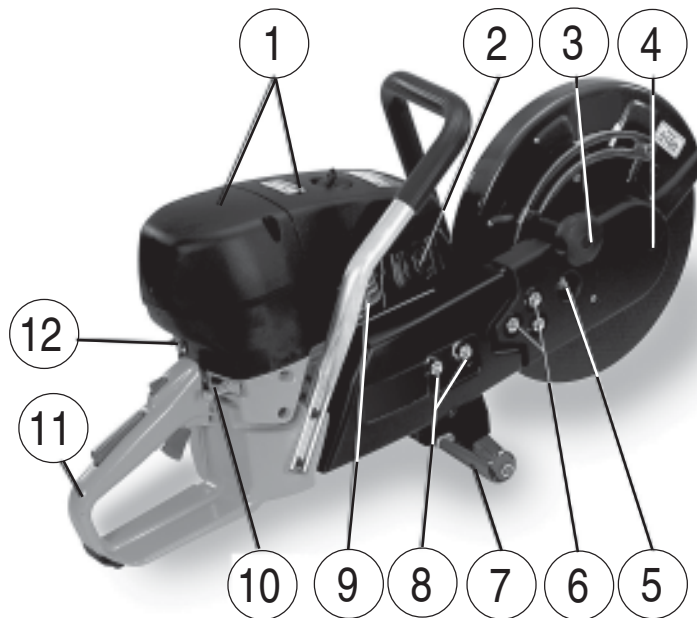

Figure 2. HS62A Cut-off Saw Components 1

Figures 2 and 3 shows the location of the basic controls or components for the Multiquip Model HS62A Cut-off Saw. Listed below is a brief explanation of each control or component.

1. **Air Filter** – Prevents dirt and debris from entering the engine air intake. Check filter periodically and keep cleaned or replace when necessary. **NEVER** run engine with a dirty air filter.
2. **Muffler** – Used to reduce noise and emissions. **NEVER!** touch muffler when engine is running. Allow engine to cool down. This component gets extremely hot!
3. **Guard Adjustmet Knob** – Allows for the adjustment of the blade guard. Turn this knob clockwise to tighten, counter-clockwise to loosen.
4. **Pulley Lock Pin Hole** – Insert a phillips head screw driver or similar tool into this hole to prevent the pulley from rotating.
5. **V-belt Tensioning Cam** – Allows for the adjustment of the V-belt. To tighten V-belt turn clockwise, to slacken turn counterclockwise.
6. **V-belt Cover (Pulley)** – Unscrew these 3 nuts to remove the pulley V-belt cover. **NEVER** operate the saw with this cover removed.
7. **Roller Wheel** – Allows for easy free movement of the saw when cutting on a flat surface.
8. **V-belt Cover (Clutch)** – Unscrew these 2 nuts to remove the clutch V-belt cover. **NEVER** operate the saw with this cover removed. It may be necessary to remove the pulley cover first before this cover can be removed.
9. **Decompression Valve** – Push inward when starting engine.
10. **Choke Lever** – Used in the starting of a cold engine, or in cold weather conditions. The choke enriches the fuel mixture.
11. **Rear Handle** – When starting engine, place right foot onto rear handle base. For normal operation always place one hand on the rear handle and the other hand on the upper handle. Always use two hands when operating the saw.
12. **Engine ON/OFF Switch** – **ON** position permits engine starting, **OFF** position stops engine operation.

HS62A CUT-OFF SAW — CONTROLS & COMPONENTS

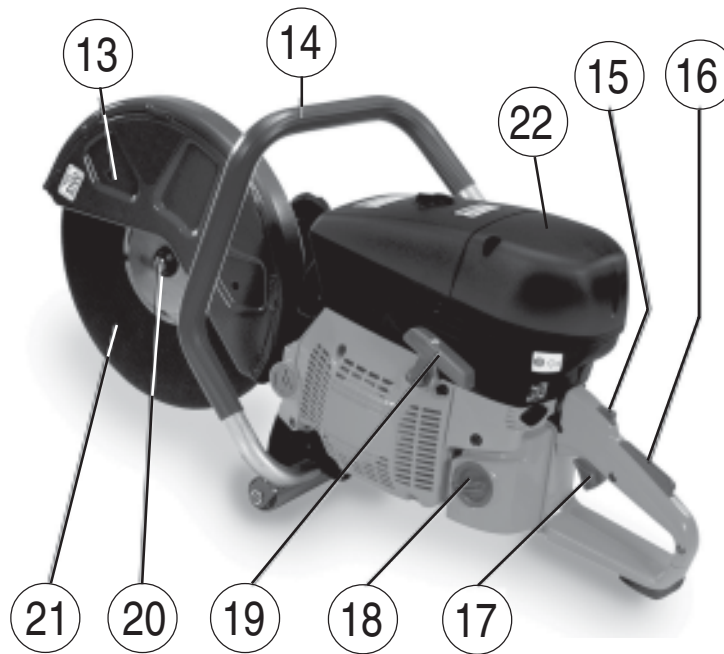

Figure 3. HS62A Cut-off Saw Components 2

13. **Blade Guard** – Covers saw blade.
14. **Front Handle** – When lifting or carrying of the saw is required, use this handle.
15. **Throttle Lock Lever** – Using your thumb, press this lever downward and squeeze the trigger lever to lock the throttle in place. Use this option only to aid starting. Squeeze the trigger lever again to unlock the throttle.
16. **Throttle Trigger Lock-out** – Press this lever downward to allow throttle trigger activation.
17. **Throttle Trigger Lever** – Squeeze this lever to start the saw blade rotation. Release the trigger lever to stop the saw blade rotation. This lever is to be used in conjunction with either the throttle lock or variable throttle levers.
18. **Fuel Filler Cap** – Remove this cap to add mixed fuel (requires a 50:1 mixture) to the fuel tank. This saw uses a 2-stroke engine. Make sure fuel cap is tightened securely. **DO NOT** over fill. See Figure 13 for correct fuel to oil mixture.
19. **Recoil Starter (pull rope)** – Manual-starting method. Pull the starter grip until resistance is felt, then pull briskly and smoothly.
20. **Blade Shaft Nut** – Loosen to remove the cutting blade from the outer and inner flanges.
21. **Cutting Blade** – Use appropriate type blades for desired cutting application.
22. **Spark Plug** – Provides spark to the ignition system. Set spark plug gap to 0.02 inch (0.5 mm). Clean spark plug once a month.

HS62A CUT-OFF SAW — BLADE INSTALLATION INSTRUCTIONS

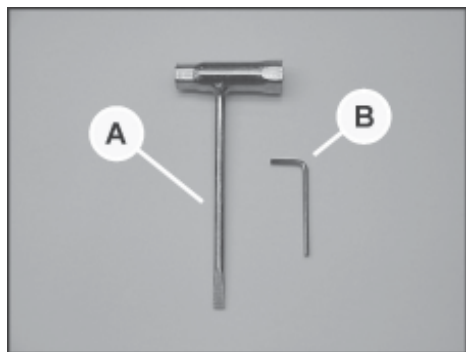

Figure 4. Tool Kit

The Multiquip *Side Winder* Cut-Off Saw comes with a Tool Kit (Figure 4) that assists you with day to day operations. You will need these tools for the assembly of your saw.

Item **A** is a versatile screwdriver/wrench that accommodates common bolt/screw and nut head sizes of your saw.

Item **B** is the wrench necessary to accommodate various allen screws.

Blade Installation Procedure

STEP 1

For proper installation, first remove the **blade shaft nut** ①, **outer flange** ②, and **inner “dual-arbor” flange** ③.

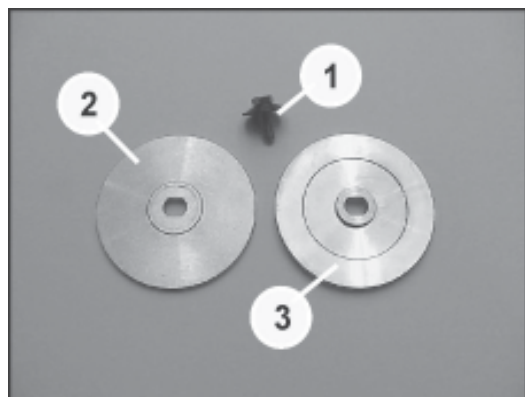

Figure 5. Inner and Outer Flanges (Removal)

STEP 2

A dual sided, “dual-arbor” **inner flange** ③ accommodates either a 20 mm or 1-inch arbor hole for operator safety and convenience. The **outer flange** ② fits on top of the cutting blade.

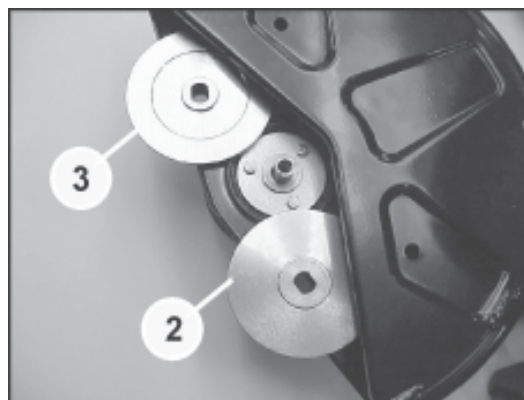

Figure 6. Inner and Outer Flanges (Placement)

STEP 3

Choose the proper **blade arbor** side of the **inner flange** (to match your cutting blade arbor) and place this selected side to the blade shaft ④.



Figure 7. Selecting the Proper Blade Arbor

STEP 4

Match the arbor side to the dimension of your blade arbor and “sandwich” between the inner and outer flanges. Tighten the blade shaft nut ① securely to hold the blade in place.



Figure 8. Securing the Cutting Blade

HS62A CUT-OFF SAW — WATER KIT INSTALLATION INSTRUCTIONS

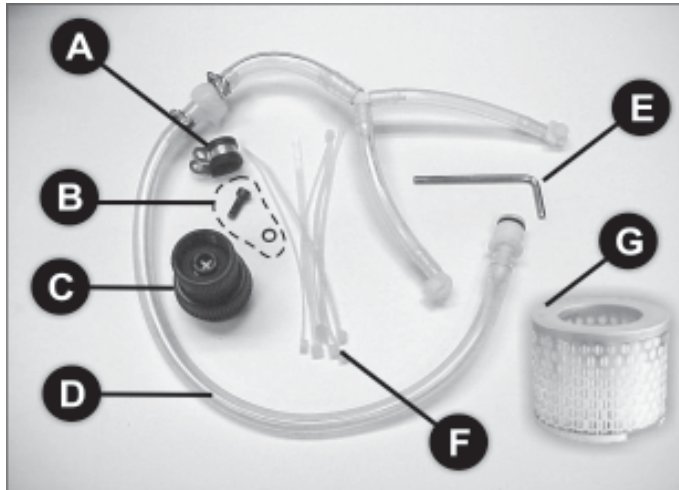

Figure 9. Water Kit Parts

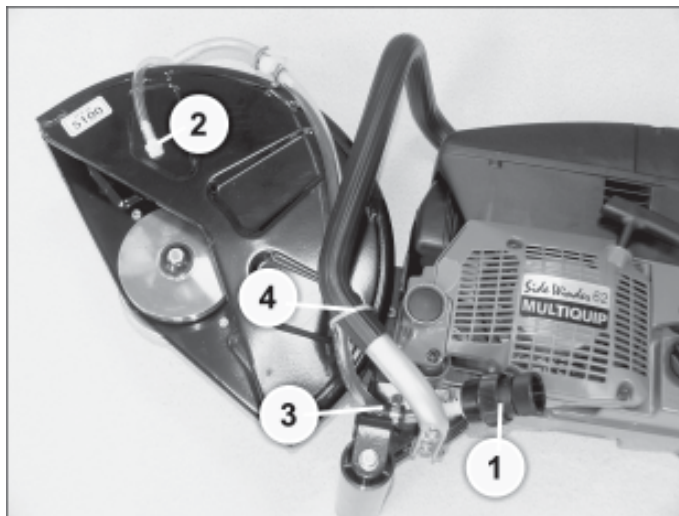

Figure 10. Water Kit Assembly Points



Figure 11. Wet Air Filter Canister

Contents of Water Kit

The contents of the Water Kit cannot be purchased separately. See Water Kit Assembly in Parts Section of this manual for Water Kit part number.

Hose Clamp **(A)**

Socket Head Cap Screw w/ Washer **(B)**

Quick Disconnect Fitting **(C)**

Water Hose **(D)**

Hex Key Tool **(E)** (Included with Tool Kit)

Plastic Ties **(F)**

Wet Air Filter Canister **(G)** (Sold Separately)

Water Kit Installation Procedure

- 1 Connect the **Quick Disconnect Fitting** **(C)** to the single end of the **Water Hose** **(D)**.
- 2 Snap fit the **Water Hose** Outlets **(D)** to the **Holes** in the **Blade Guard**. Orient the **Water Hose** **(D)** through the **Front Handle**.
- 3 Loop the **Hose Clamp** **(A)** around the **Water Hose** **(D)** and fasten the clamp to the **Roller Bar Support Arm** using the **Socket Head Cap Screw w/ Washer** **(B)**, and **Hex Key Tool** **(E)**.
- 4 Use the **Plastic Ties** **(F)** as preferred to further secure the hose fittings and water hose to the saw.
- 5 When using the Water Kit option for your saw, the **Dry Air Filter Canister** **MUST** be replaced with the **Wet Air Filter Canister** **(G)** (See Air Filter Kit Assembly in Parts Section of this manual).

PREPARATION / PRE-INSPECTION

1. Read and fully understand this manual, the safety instructions in particular, and the engine manufacturer's manual supplied with the saw.



2. Select the correct blade for each application. If abrasive blades are used, **MAKE CERTAIN** they are designed for use on a concrete floor saw. They must be reinforced and have a hole for the driving pin. When wet cutting with an abrasive blade, **MAKE CERTAIN** the blade is intended for wet cutting. Water will destroy a dry cut abrasive blade. Some diamond blades require water cooling and failure to do so will destroy them almost immediately. Other diamond blades can be used with or without water.
3. Handle all blades with care and **NEVER** use a damaged blade. **NEVER** use an abrasive blade that has been dropped.

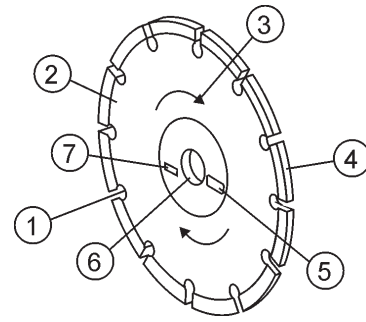

Figure 12. Diamond Blade

BLADES

Saw blades, or cutting disks, are available in either an abrasive design or as diamond blades. Either blade will work on the HS62A CUT-OFF SAW, however, diamond blades are recommended. Ask your dealer about your specific cutting application.

SAW BLADE INSPECTION



WARNING



Failure to thoroughly inspect the diamond blade (Figure 12) for operational safety could result in damage to the blades or the saw and may cause injury to the user or others in the operating area.

1. **Stress Relief Holes (Gullets)** - Check the steel core for cracks that may have propagated from the slots and/or gullets. Cracks indicate extreme fatigue failure and if sawing continues, catastrophic failure will occur.

2. **Edge of the Steel Core** - Check the diameter edge for discoloration (blue oxidation) indicating an overheating condition caused by insufficient cooling water/air. Overheating of blades may lead to loss of core tension and/or increase the possibility for blade failure. Make sure the steel core's width is uniform about the rim of the blade, and not succumbing to an "under-cutting" condition brought about by highly abrasive material or improper under-cutting core protection
3. **Directional Arrow** - Ensure that the blade is oriented properly on the blade shaft for sawing. Reference the directional arrow on the blade and place it so the direction of rotation "downcuts" with the turn of the shaft.
4. **Diamond Segment or Rim** - Ensure there are no cracks, dings, or missing portions of the diamond segment/rim. **DO NOT use a blade that is missing a segment or a portion of the rim.** Damaged and/or missing segments/rims may cause damage to your saw or injury to the user or others in the operating area.
5. **Specifications** - Ensure that the blade specifications, size, and diameter properly match up to sawing operations. Utilizing a blade not matched properly to the task may result in poor performance and/or blade damage.
6. **Arbor Hole** - It is essential that the arbor hole diameter properly matches the blade, and that it is free from distortion. Correct blade flanges (collars) must be used. The inside face of the flanges must be clean and free of debris. An out-of-round arbor condition will cause damage to the blade and the saw.
7. **MAX RPM** - This RPM reference is the maximum safe operating speed for the blade selected. **NEVER** exceed the max RPM on the diamond blade. Exceeding the maximum RPM is dangerous and may cause poor performance and may damage the blade.

HS62A CUT-OFF SAW — INITIAL START-UP/OPERATION

INITIAL START-UP

CAUTION

DO NOT attempt to operate the saw until the Safety, General Information and Inspection sections of this manual have been read and thoroughly understood. Depending on engine manufacturer, operating steps may vary. See engine manufacturer's operating manual.

CAUTION

NEVER operate the saw in a confined area or enclosed area structure that does not provide ample **free flow of air**.



ALWAYS wear approved eye and hearing protection before operating the saw.

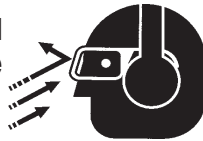

NEVER place hands or feet inside the belt guard or blade guard while the engine is running. **ALWAYS** shut the engine down before performing any kind of maintenance service on the saw.



Explosive Fuel

Fuel Check

Motor fuels are highly flammable and can be dangerous if mishandled. **DO NOT** smoke while refueling. **DO NOT** attempt to refuel the saw if the engine is **hot!** or **running**.



1. Remove the fuel cap located on the side of the saw.
2. Visually inspect to see if fuel level is low. If fuel is low, replenish with **fuel oil mixture** as shown in Figure 13.
3. When refueling, be sure to use a strainer for filtration. **DO NOT** top-off fuel. Wipe up any spilled fuel.

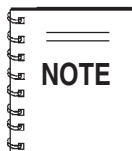

This saw uses a 2-stroke engine which requires a mixture of **premium 92 octane** unleaded gasoline and smoke free 2-stroke motor oil. See Figure 13.

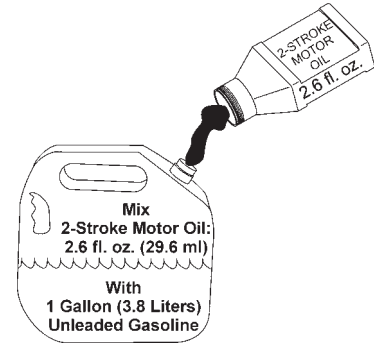
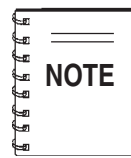

Figure 13. Fuel to Oil Mixture



For correct fuel to oil mixture, add 2.6 fl. oz (29.6 ml) of 2-stroke motor oil to 1 gallon (3.8 liters) of **premium 92 octane unleaded gasoline**. For a **5 gallon** can of **premium** unleaded gasoline add 13 fl. oz (384 ml) of 2-stroke motor oil.

A bottle (2.6 fl. oz) of smokeless 2-stroke motor oil **cannot be purchased separately**. Only a case of 36 individual bottles can be purchased. When ordering use Multiquip P/N 00325.

Starting

1. Place the engine ON/OFF switch in the **ON** position
2. Using your thumb, press down on the throttle lock lever, while squeezing the throttle trigger. This will lock the throttle in the **half-throttle** position.
3. Pull the choke lever all the way out to the **CLOSED** position.
4. Pull the **decompression button** inward.
5. Place the saw on level ground. Make sure the saw blade is free to rotate and will not come into contact with any foreign objects.
6. Hold the front handle firmly with the left hand and put your right foot onto the base of the rear handle.

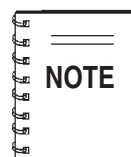

The **CLOSED** position of the choke lever enriches the fuel mixture for starting a **COLD** engine. The **OPEN** position provides the correct fuel mixture for normal operation after starting, and for restarting a warm engine.

HS62A CUT-OFF SAW — INITIAL START-UP/OPERATION

7. Grasp the **starter grip** and slowly pull it out. The resistance becomes the hardest at a certain position, corresponding to the compression point. Pull the starter grip briskly and smoothly for starting.
8. If the engine has started, slowly return the choke lever to the "**OPEN**" position. If the engine has not started repeat steps 1 through 9.
9. Squeeze the throttle lever trigger to release it from the **half-throttle** position.
10. Before the saw is placed into operation, run the engine for several minutes. Check for fuel leaks, and noises that would associate with a loose guards and/or covers.

OPERATION

WARNING

ALWAYS cut with the saw at **FULL THROTTLE**. Attempting to cut with the saw at less than full throttle could cause the blade to bind or stop abruptly in the slab resulting in serious injury to the operator or others in the area.

WARNING

ALWAYS keep clear of **rotating** or **moving** parts while operating this equipment.

2. To begin sawing, lower the rotating blade allowing it to cut to the preset depth.
3. When blade has reached full cutting depth, slowly walk behind the saw at a rate that will allow the engine to operate without losing optimum RPM.

CAUTION

DO NOT try to cut faster than the blade will allow. Cutting too fast will cause the blade to rise up out of the cut. Improper cutting rate can decrease the life of the engine and blades.

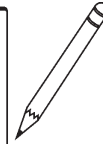
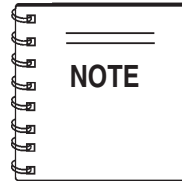

Mark the cutting line clearly and always saw in a **STRAIGHT LINE ONLY**.

4. When the end of the cut has been reached, raise the blade out of the cut .
5. If cutting is complete, turn the engine off and wait for the blade to stop rotating.

Shut-down

1. Let the engine idle for 3-5 minutes.
2. Place the engine ON/OFF switch to the **OFF** position
3. Wait for the blade to stop spinning before handling the saw.
4. **DO NOT** touch the cutting blade it is very **hot!**, allow it to cool, severe burn condition exists.

V-Belt Changing Procedure

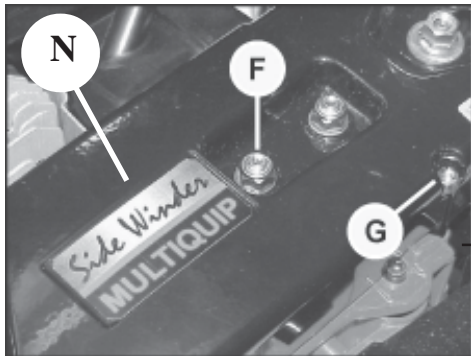

Figure 14. Belt Guard Cover Removal

Remove the 2 hex nuts **F** and hex screw and washer **G** to gain access to the V-belt on the clutch side. Remove V-belt cover **N**.

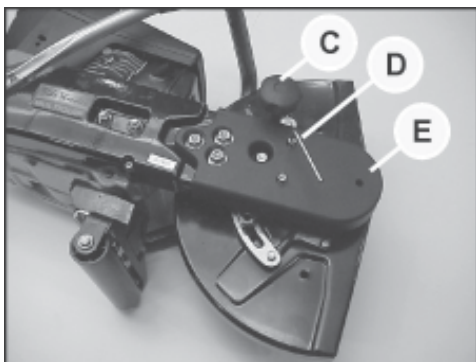

Figure 15. Re-Installing Cover Guard

Remove the 2 hex nuts **D** and hex screw and guard adjustment knob **C** to gain access to the V-belt on the spindle side. Remove the Cover Guard **E**.

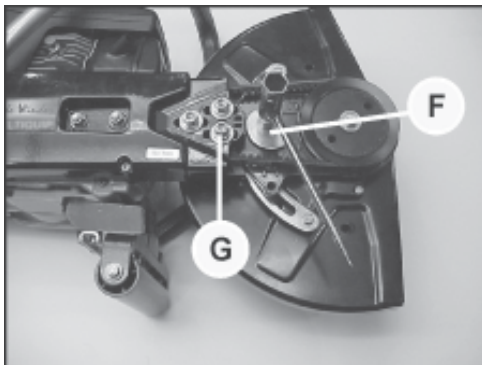

Figure 16. V-Belt Tensioning

Using the provided wrench, loosen the three nuts **G** to reduce the tension on the V-belt, then turn the **V-belt Tensioning Cam** **F** until the V-belt is completely slacked.

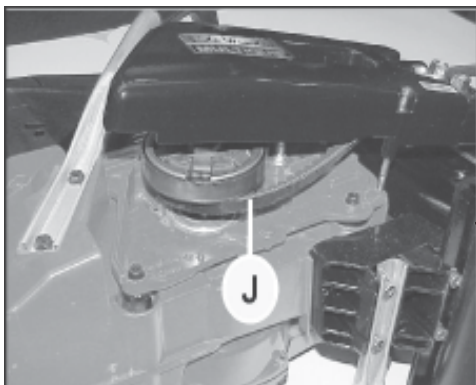

Figure 17. Drive V-Belt

Remove the V-belt **J** from the *clutch and spindle pulleys*. Install the new V-belt around both pulleys. It is essential that the drive V-belt is properly positioned around both the clutch and spindle pulleys.

V-Belt Changing Procedure (continued)

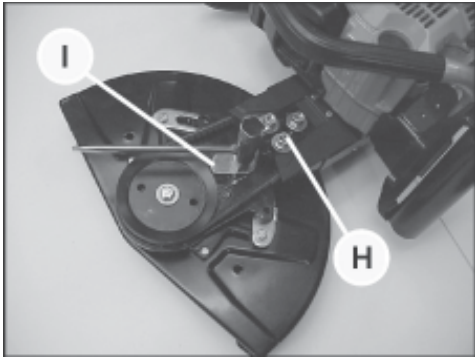

Figure 18. Reversing the Cutting Arm

Re-tension the V-belt by turning the *belt tensioning cam* **I**. The V-belt should remain in tension.

Fully tighten the three nuts **H** that lock the V-belt into the proper tensioning position.

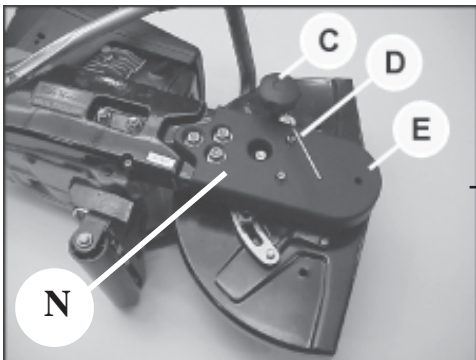
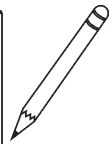
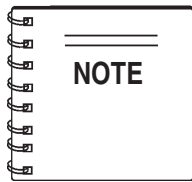

Figure 19. Re-Installing Cover Guard

Re-install the *guard* **E** and *V-belt* **N** covers. Fully tighten the two cap screws **D** and reinstall the adjustment knob **C**.

Reversing the Cutting Arm Procedure



This assembly procedure permits the operator to reorient the **cutting blade** closer to a wall, column and/or object.

The Multiquip *Side Winder* Cut-Off Saw comes with a Tool Kit (Figure 16) that assist you with day to day operations. You will need these tools for the maintenance of your saw.

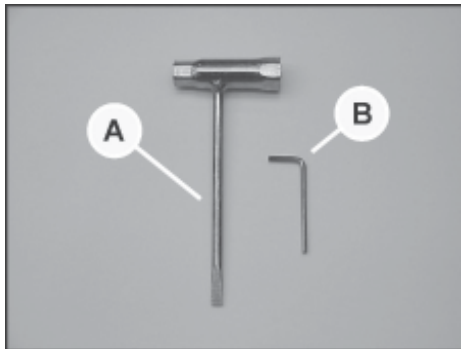

Figure 20. Tool Kit

Item **A** is a versatile screwdriver/wrench that accommodates common bolt/screw and nut head sizes of your saw.

Item **B** is the wrench necessary to accommodate various allen screws.

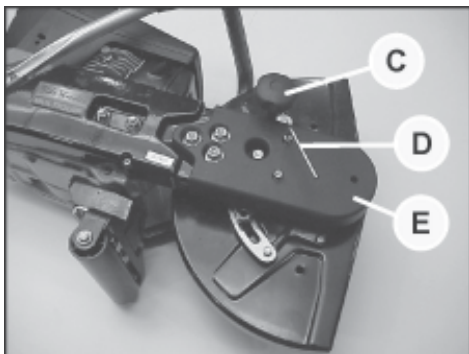

Figure 21. Inside Center Cutting Position

This position displays the **cutting blade on the inside** (center) cutting position. To reverse the blade position continue with the following steps:

Remove the following items from the **Cutting Arm Assembly** to expose the V-belt:

- Guard Adjustment Knob **C**
- Two Cap Screws **D**
- Cover Guard **E**

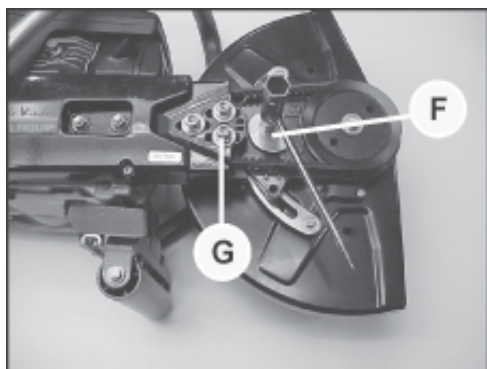
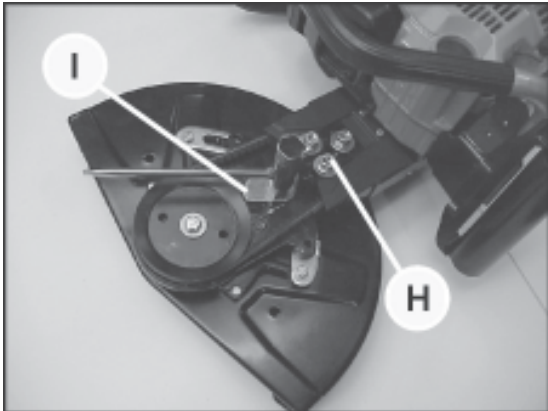

Figure 22. Belt Tensioning Cam

Loosen the **belt tensioning cam** **F** and remove the three nuts **G**. This will take tension off the V-belt, and permit you to reverse the **cutting arm**.

Reversing the Cutting Arm Procedure (continued)



Reverse the **cutting arm** 180 degrees as shown in the Figure 23, and re-tension the V-belt by turning the **belt tensioning cam I**. The V-belt should remain in tension.

Fully tighten the three nuts **H** that lock the V-belt into the proper tensioning position.

Figure 23. Reversing the Cutting Arm

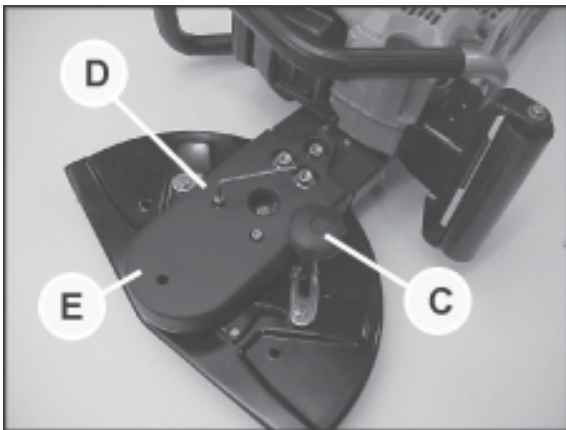

Re-attach the **cover guard E** with the 2 cap screws **D**, and reconnect the **guard adjustment knob C**.

Figure 24. Re-attaching Cover Guard

HS62A CUT-OFF SAW — MAINTENANCE (AIR/FUEL FILTER)

Air/Fuel Filter Maintenance Procedures

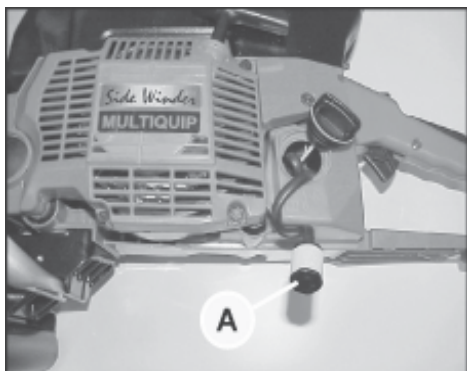

Figure 25. Fuel Filter

Check the **fuel filter** **A** located inside the fuel tank periodically for dirt/debris build up. It is recommended to change the fuel filter every **50 tanks of fuel**.

This engine is a 2-stroke gasoline engine requiring a specific fuel to oil mixture of 50:1(2%). It is recommended to use an unleaded gasoline rated at 92 octane (**premium**) with an oil for use on 2-stroke engines only. See Figure 13.

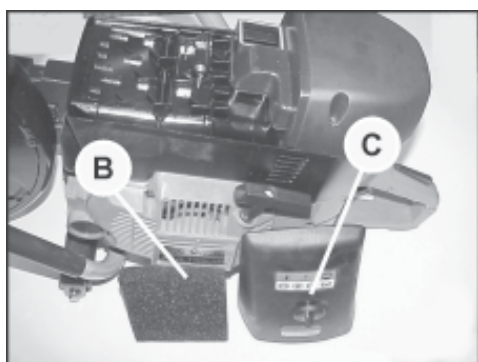

Figure 26. Pre-Filter

It is highly recommended to keep a supply of spare **pre-filters** on hand. Maintaining the **foam pre-filter**, and regular exchanges will prolong the life of the **main filter element**.

Every 8 hours of operation, remove the **pre-air cleaner cover** **C** and wash the foam **pre-cleaner** **B** in warm fresh soapy water. Let dry thoroughly. When dry, completely coat the filter with only an approved **foam filter oil**.

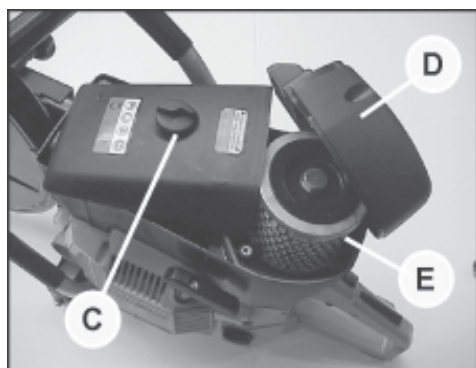

Figure 27. Main Filter Element

Every 8 hours of operation, remove the **covers** **C** and **D** and inspect the **main filter element**. Clean the **main filter element** **E** by vigorously shaking out and dusting off with a soft brush. **DO NOT** air blast clean this element with compressed gas.

The main filter element should be replaced after **three pre filter changes**

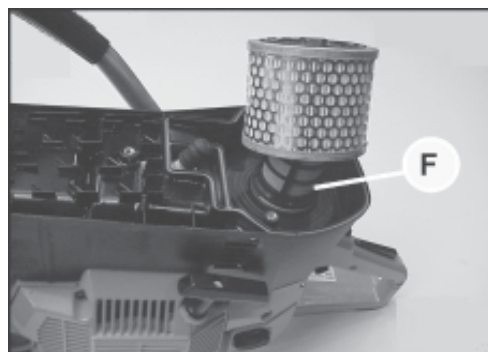

Figure 28. Supplementary Filter

Every 8 hours of operation, inspect the **supplementary filter element** **F**. Clean the **supplementary filter element** **F** by vigorously shaking out and dusting off with a soft brush. **DO NOT** air blast clean this element with compressed gas.

The **supplementary filter element** should be replaced after **three pre filter changes**.

HS62A CUT-OFF SAW — TROUBLESHOOTING (BLADE)

TABLE 3. BLADE TROUBLESHOOTING

SYMPTOM	POSSIBLE PROBLEM	SOLUTION
Blade slows or stops cutting.	Blade too hard for the material being cut?	Consult Dealer or Multiquip for correct blade. Try cutting very soft material (sandstone, silica brick, cinder block) to "Redress" the blade.
	Engine torque diminished because of loose V-belt?	Tighten and/or replace V-Belts.
	Insufficient engine power?	Check throttle setting.
	Improper direction of rotation?	Check that the blade is properly oriented and rotational arrow points in a "Down-Cutting" direction.
	Blade is slipping on the blade shaft?	Check that the blade & flange pin are properly installed on the blade shaft.
Blade does not cut straight and/or true.	Blade being used on misaligned saw?	Check blade shaft bearings and alignment integrity.
	Blade is excessively hard for the material being cut?	Check specification of the blade with the material being cut. Consult Dealer or Multiquip for information.
	Blade being used at improper RPM?	Ensure blade surface feet per minute speed (SFPM) is approximately 6,000.
	Blade improperly mounted on arbor shoulders and flanges?	Ensure blade is properly affixed on the blade shaft.
	Excessive force applied to blade while cutting?	DO NOT force the blade in the cut. Apply a slow and steady pace when sawing.
Blade discoloring, crackling and/or wearing excessively.	Blades too hard for the material being cut?	Consult Dealer or Multiquip for correct blade. Try cutting very soft material (sandstone, silica brick, cinder block) to "Redress" the blade.
	Blade improperly mounted on arbor shoulders and flanges?	Ensure blade is properly affixed on the blade shaft.
	Blade not receiving enough cooling water or air?	Ensure proper flow & volume of water is provided for wet cutting blades. Ensure sufficient cooling air is circulated about a dry cutting blade.
	Arbor hole out of round?	Ensure blade is properly affixed on the blade shaft.
	Incorrect blade chosen for material being cut?	Check specification of the blade with the material being cut. Consult Dealer or Multiquip for information.
	Excessive force applied to blade while cutting?	DO NOT force the blade in the cut. Apply a slow and steady pace when sawing.

HS62A CUT-OFF SAW — TROUBLESHOOTING (ENGINE)

TABLE 4. TROUBLESHOOTING (ENGINE)

SYMPTOM	POSSIBLE CAUSE	SOLUTION
Difficult to start, "fuel is available, but no SPARK at spark plug".	Spark plug bridging?	Check gap, insulation or replace spark plug.
	Carbon deposit on spark plug?	Clean or replace spark plug.
	Short circuit due to deficient spark plug insulation?	Check spark plug insulation, replace if worn.
	Improper spark plug gap?	Set to proper gap.
	Ignition coil defective?	Replace ignition coil.
Difficult to start, "fuel is available, and SPARK is present at the spark plug".	ON/OFF switch is shorted?	Check switch wiring, replace switch.
	Improper spark gap, points dirty?	Set correct spark gap and clean points.
	Spark plug wire broken or short circuiting?	Replace defective spark plug wiring.
Difficult to start, "fuel is available, spark is present and compression is normal".	Wrong fuel type?	Flush fuel system, and replace with correct type of fuel.
	Water or dust in fuel system?	Flush fuel system.
	Air cleaner dirty?	Clean or replace air cleaner.
	Choke Open?	Close Choke.
Difficult to start, "fuel is available, spark is present and compression is low".	Suction/exhaust valve stuck or protruded?	Re-seat valves.
	Piston ring and/or cylinder worn?	Replace piston rings and/or piston.
	Cylinder head and/or spark plug not tightened properly?	Torque cylinder head bolts and spark plug.
	Head gasket and/or spark plug gasket damaged?	Replace head and/or spark plug gaskets.
No fuel present at the carburetor.	Fuel not available in fuel tank (tank empty)?	Fill with correct type of fuel.
	Fuel filter clogged?	Replace fuel filter.
	Fuel tank cap breather hole clogged?	Clean or replace fuel tank cap.
	Air in fuel line?	Bleed fuel line.

HS62A CUT-OFF SAW — TROUBLESHOOTING (ENGINE)

TABLE 4. TROUBLESHOOTING (ENGINE, CONTINUED)

SYMPTOM	POSSIBLE CAUSE	SOLUTION
"Weak in power" compression is proper and does not misfire.	Air cleaner not clean?	Clean or replace air cleaner.
		Rebuild carburetor.
	Defective spark plug?	Clean or replace spark plug.
	Improper spark plug gap?	Set to proper gap.
"Weak in power" compression is proper but misfires.	Water in fuel system?	Flush fuel system and replace with correct type fuel.
	Ignition coil defective?	Replace ignition coil.
	Dirty spark plug?	Clean or replace spark plug.
Engine overheats.	Wrong fuel type?	Flush fuel system, and replace with correct type of fuel.
	Spark plug heat value improper?	Replace with correct type of spark plug.
	Cooling fins dirty?	Clean cooling fins.
Rotational speed fluctuates.	Fuel flow restricted?	Check entire fuel system for leaks or clogs.
Recoil starter malfunction.	Recoil mechanism clogged with dust and dirt?	Clean recoil assembly with soap and water.
	Spiral spring loose?	Consult Dealer.

For *Side Winder* HS Series Cut-Off Saws

□ HS62A

DRY FILTER KITS



HS62FK1A

[Includes 1 ea.]

HS52020270R- Foam Filter
HS018600125R- Paper Filter
HS018600056AR - Inner Filter

HS62FK5A

[Includes 5 ea.]

HS52020270R- Foam Filter
HS018600125R - Paper Filter
HS018600056AR - Inner Filter

HS62FK10A

[Includes 10 ea.]

HS52020270R- Foam Filter
HS018600125R - Paper Filter
HS018600056AR - Inner Filter

WET FILTER



* Replaces *DRY* Air Filter Canister When Using Water & Standard Water Kit (provided)



HS099900778A

[Includes 1 ea.]

HS62A CUT-OFF SAW — EXPLANATION OF PARTS SECTION REMARKS

The following section explains the different symbols and remarks used in the Parts section of this manual. Use the help numbers found on the back page of the manual if there are any questions.

The contents and part numbers listed in the parts section are subject to change **without notice**. Multiquip does not guarantee the availability of the parts listed.

Sample Parts List:

NO.	PART NO.	PART NAME	QTY.	REMARKS
1	12345	BOLT	1	INCLUDES ITEMS W/*
2*		WASHER, 1/4 IN.		NOT SOLD SEPARATELY
2*	12347	WASHER, 3/8 IN.	1	MQ-45T ONLY
3	12348	HOSE	A/R ..	MAKE LOCALLY
4	12349	BEARING	1	S/N 2345B AND ABOVE

NO. Column

Unique Symbols - All items with same unique symbol (*, #, +, %, or >) in the number column belong to the same assembly or kit, which is indicated by a note in the “Remarks” column.

Duplicate Item Numbers - Duplicate numbers indicate multiple part numbers are in effect for the same general item, such as different size saw blade guards in use or a part that has been updated on newer versions of the same machine.

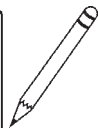
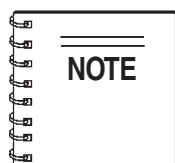

When ordering a part that has more than one item number listed, check the remarks column for help in determining the proper part to order.

PART NO. Column

Numbers Used - Part numbers can be indicated by a number, a blank entry, or TBD.

TBD (To Be Determined) is generally used to show a part that has not been assigned a formal part number at time of publication.

A blank entry generally indicates that the item is not sold separately or is not sold by Multiquip. Other entries will be clarified in the “Remarks” Column.

QTY. Column

Numbers Used - Item quantity can be indicated by a number, a blank entry, or A/R.

A/R (As Required) is generally used for hoses or other parts that are sold in bulk and cut to length.

A blank entry generally indicates that the item is not sold separately. Other entries will be clarified in the “Remarks” Column.

REMARKS Column

Some of the most common notes found in the “Remarks” Column are listed below. Other additional notes needed to describe the item can also be shown.

Assembly/Kit - All items on the parts list with the same unique symbol will be included when this item is purchased.

Indicated by:
“INCLUDES ITEMS W/(unique symbol)”

Serial Number Break - Used to list an effective serial number range where a particular part is used.

Indicated by:
“S/N XXXXX AND BELOW”
“S/N XXXX AND ABOVE”
“S/N XXXX TO S/N XXX”

Specific Model Number Use - Indicates that the part is used only with the specific model number or model number variant listed. It can also be used to show a part is NOT used on a specific model or model number variant.

Indicated by:
“XXXXX ONLY”
“NOT USED ON XXXX”

“Make/Obtain Locally” - Indicates that the part can be purchased at any hardware shop or made out of available items. Examples include battery cables, shims, and certain washers and nuts.

“Not Sold Separately” - Indicates that an item cannot be purchased as a separate item and is either part of an assembly/kit that can be purchased, or is not available for sale through Multiquip.

HS62A CUT-OFF SAW — SUGGESTED SPARE PARTS

SUGGESTED SPARE PARTS

HS62A SIDEWINDER CUT-OFF SAW

1 to 3 Units

Qty.	P/N	Description
1	HS52022011A	STARTER ASSEMBLY
3	HS098000079R	ROPE, STARTER
1	HS50140060	HANDLE, ROPE
1	HS098000060A	SPRING & CASE, STARTER
6	HS3055118	SPARK PLUG
1	HS50012023AR	CLUTCH ASSEMBLY
1	HS52022005	FUEL CAP, W/O-RING
3	HS50010218	FILTER, FUEL
1	HS52010092	THROTTLE TRIGGER LEVER
1	HS52010077	THROTTLE LOCK LEVER
1	HS52020037	CHOKE LEVER
1	HS52010022A	COVER, BELT GUARD
3	HS3918013	WASHER, BELT COVER
3	HS3914010	NUT, BELT COVER
3	HS52020020	V-BELT
2	HS018600235	FLANGE, ARBOR
2	HS018600236A	FLANGE, ARBOR
2	HS52010177	SCREW AND WASHER, ARBOR
2	HS52010062A	KNOB, ADJ. GUIDE
2	HS3833080	WASHER, ADJ. GUIDE
2	HS52010045	SPACER, ADJ. GUIDE
2	HS52010013	LOCK, GUIDE BLADE GUARD
1	HS52012024B	FLANGE, PRE-FILTER CAP
1	HS52010014B	SUPPORT FILTER
2	HS3802002A	SCREW, FILTER SUPPORT
1	HS330000010	O-RING, FLANGE PRE-FILTER
1	HS018600090A	GASKET, AIR FILTER LOWER
18	HS018600125R	AIR FILTER
6	HS018600056AR	FILTER, AIR INNER
18	HS52020270R	PRE-FILTER, FOAM
3	HS4191240	TOOL KIT
3	HS099900778A	WET, AIR FILTER
3	HS52010082	BREATHER ASSEMBLY
1	00325	CASE, OIL 2-STROKE NON-SMOKE - 36 BOTTLES

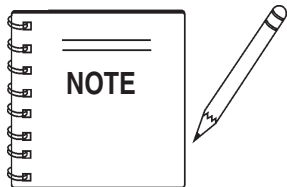

The contents of this parts catalog are subject to change without notice.

HS62A CUT-OFF SAW — MUFFLER ASSY.

MUFFLER ASSY.

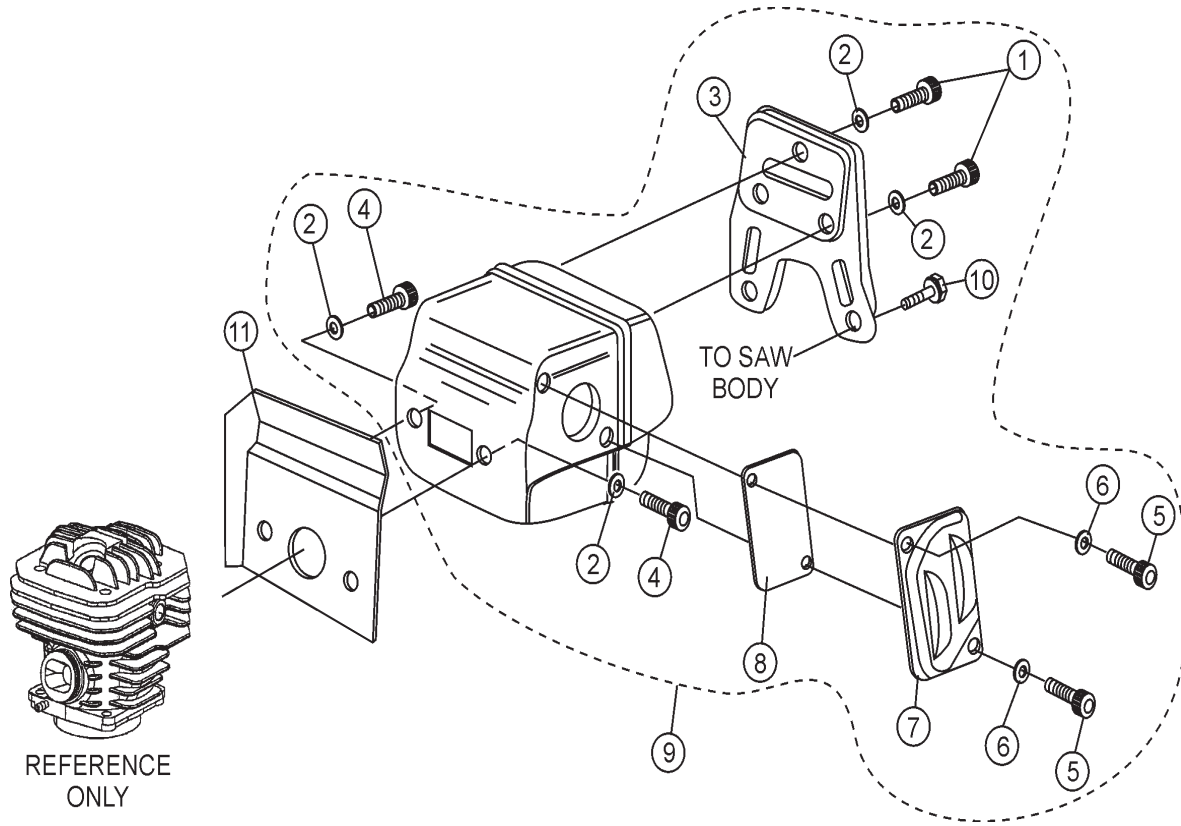

HS62A CUT-OFF SAW — MUFFLER ASSY.

MUFFLER ASSY.

<u>NO.</u>	<u>PART NO.</u>	<u>PART NAME</u>	<u>QTY.</u>	<u>REMARKS</u>
1*	HS3801052	SCREW	3	
2*	HS3033074	WASHER	5	
3*	HS50010145	COVER, MUFFLER	1	
4*	HS3801045	SCREW	2	
5*	HS005100913B	SCREW	2	
6*	HS3833073	WASHER	2	
7*	HS50010198	DEFLECTOR, MUFFLER	1	
8*	HS50010197	SCREEN	1	
9	HS52010441	MUFFLER ASSEMBLY	1	INCLUDES ITEMS W/*
10*	HS097000092A	SCREW	2	
11	HS50010058A	GASKET, MUFFLER	1	

HS62A CUT-OFF SAW — RECOIL START ASSY.

RECOIL START ASSY.

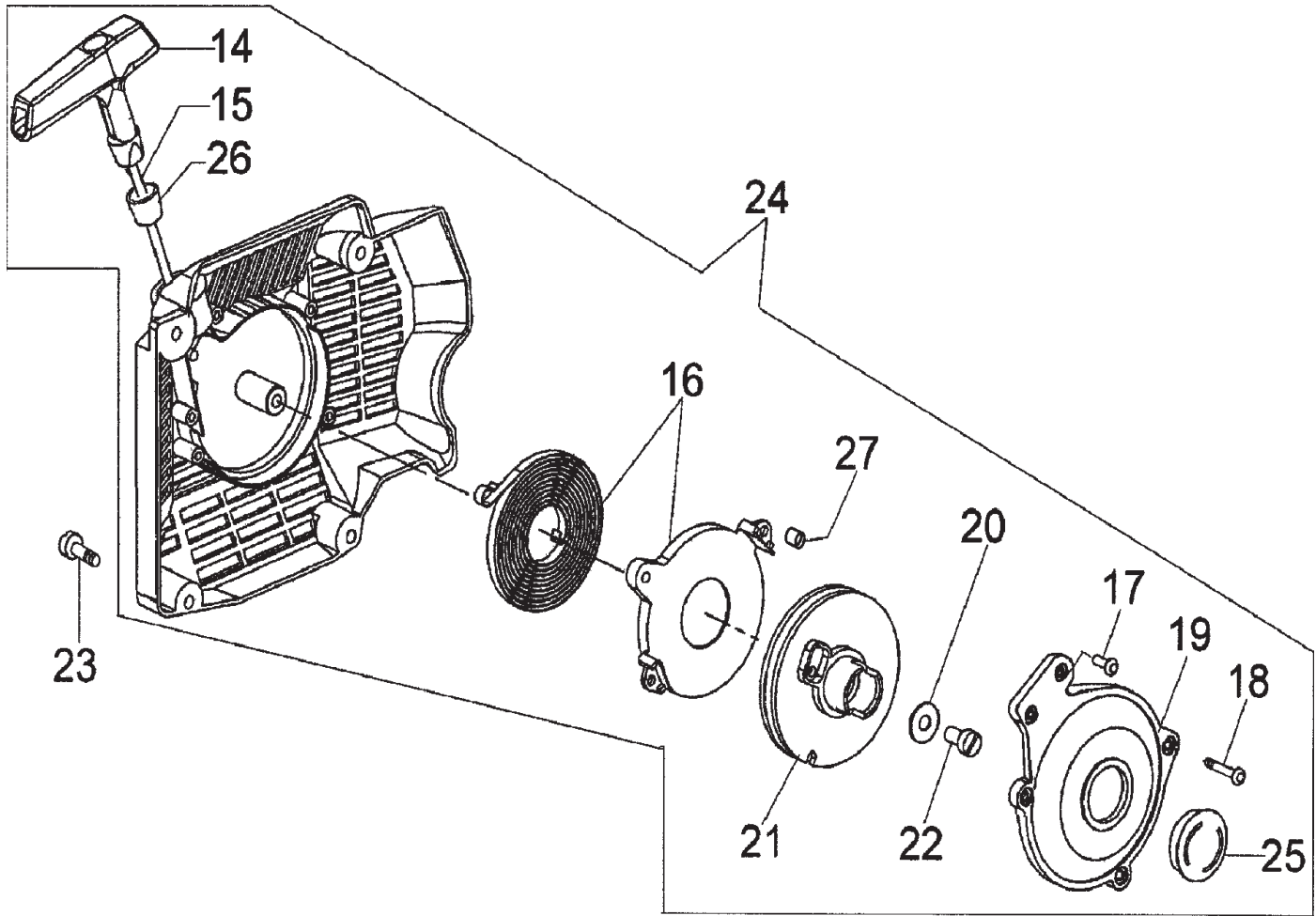

HS62A CUT-OFF SAW — RECOIL START ASSY.

RECOIL START ASSY.

<u>NO.</u>	<u>PART NO.</u>	<u>PART NAME</u>	<u>QTY.</u>	<u>REMARKS</u>
14*	HS50140060	HANDLE, STARTER ROPE	1	
15*	HS098000079R	ROPE, STARTER	1	
16*	HS098000060A	SPRING AND CASE, STARTER	1	
17*	HS3960017	SCREW	4	
18*	HS3960116	SCREW	1	
19*	HS50140055	COVER	1	
20*	HS3918006	WASHER	1	
21*	HS52010439B	PULLEY, STARTER	1	
22*	HS3908036	SCREW	1	
23	HS097000092A	SCREW	4	
24	HS52022011A	STARTER ASSEMBLY	1	INCLUDES ITEMS W/*
25*	HS52010410	CAP	1	
26*	HS50140056	CAP	1	
27*	HS52010404	SPACER	1	

HS62A CUT-OFF SAW — CRANKCASE ASSY.

CRANKCASE ASSY.

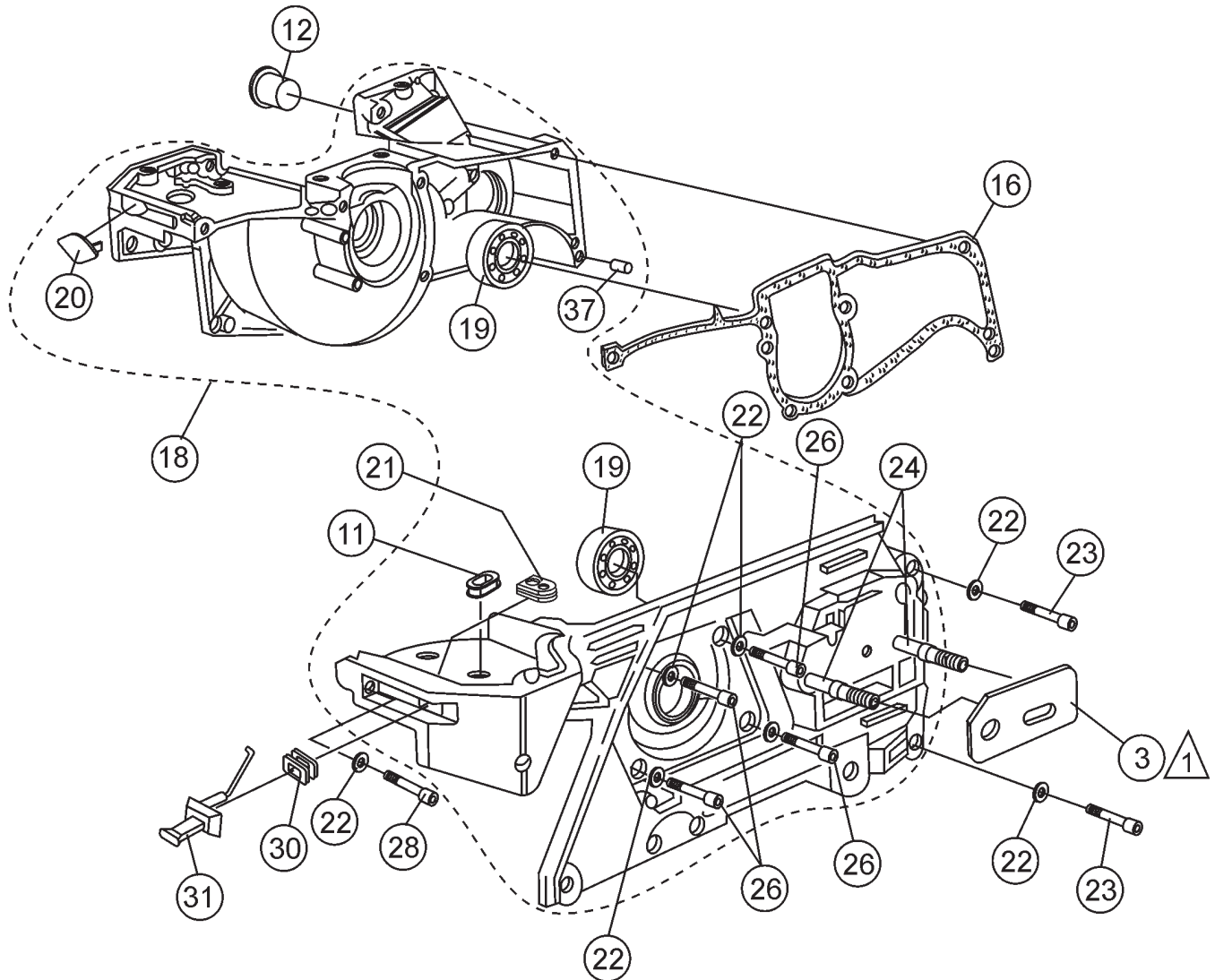

NOTES:

- △ 1 ITEM 3, ARM SUPPORT PLATE
IS INCLUDED WITH V-BELT COVER
P/N HS52020240

HS62A CUT-OFF SAW — CRANKCASE ASSY.

CRANKCASE ASSY.

<u>NO.</u>	<u>PART NO.</u>	<u>PART NAME</u>	<u>QTY.</u>	<u>REMARKS</u>
3	HS52010312	PLATE	1	
11	HS52020014	GROMMET	1	
12	HS52020040	CAP	1	
16	HS50010047AR	GASKET, CRANKCASE	1	
18	HS52020273	CRANKCASE W/ BEARING ASSY	1	INCLUDES ITEMS W/*
19*	HS3034012	BEARING, CRANKCASE	2	
20	HS52020013	CAP	1	
21	HS50010029	GROMMET	1	
22	HS3833073	WASHER	7	
23	HS006100303	SCREW	2	
24	HS097000080BR	BAR STUD, CRANKCASE	2	
26	HS3801015	SCREW	4	
28	HS005100987	SCREW	1	
30	HS097000057	GROMMET	1	
31	HS52020037	CHOKE LEVER	1	
37*	HS3023008	PIN	2	

HS62A CUT-OFF SAW — V-BELT COVER (CLUTCH SIDE) ASSY.

V-BELT COVER (CLUTCH SIDE) ASSY

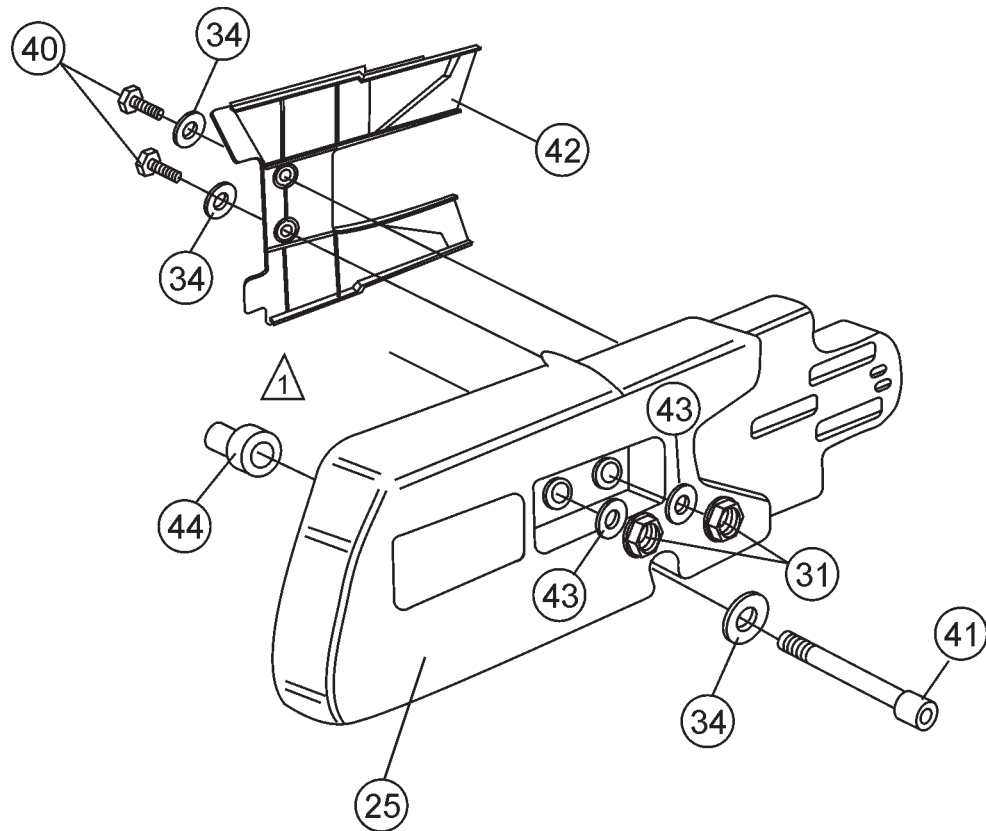

NOTES:

-  ARM SUPPORT PLATE P/N HS52010312 IS INCLUDED WITH V-BELT COVER, ITEM 25. SEE CRANKCASE ASSY. FOR SUPPORT PLATE ORIENTATION.

HS62A CUT-OFF SAW — V-BELT COVER (CLUTCH SIDE) ASSY.

V-BELT COVER (CLUTCH SIDE) ASSY.

<u>NO.</u>	<u>PART NO.</u>	<u>PART NAME</u>	<u>QTY.</u>	<u>REMARKS</u>
25	HS52020240	V-BELT COVER, (CLUTCH SIDE)	1	
31	HS50010148R	NUT	2	
34	HS3833073	WASHER	3	
40	HS3806021A	SCREW	2	
41	HS3801066	SCREW	1	
42	HS52020019	GUARD, BELT INNER	1	
43	HS3916008R	WASHER	2	
44	HS006000300	BUSHING	1	

HS62A CUT-OFF SAW — V-BELT COVER (PULLEY) /BLADE GUARD ASSY.

V-BELT COVER (PULLEY-SIDE)/BLADE GUARD ASSY.

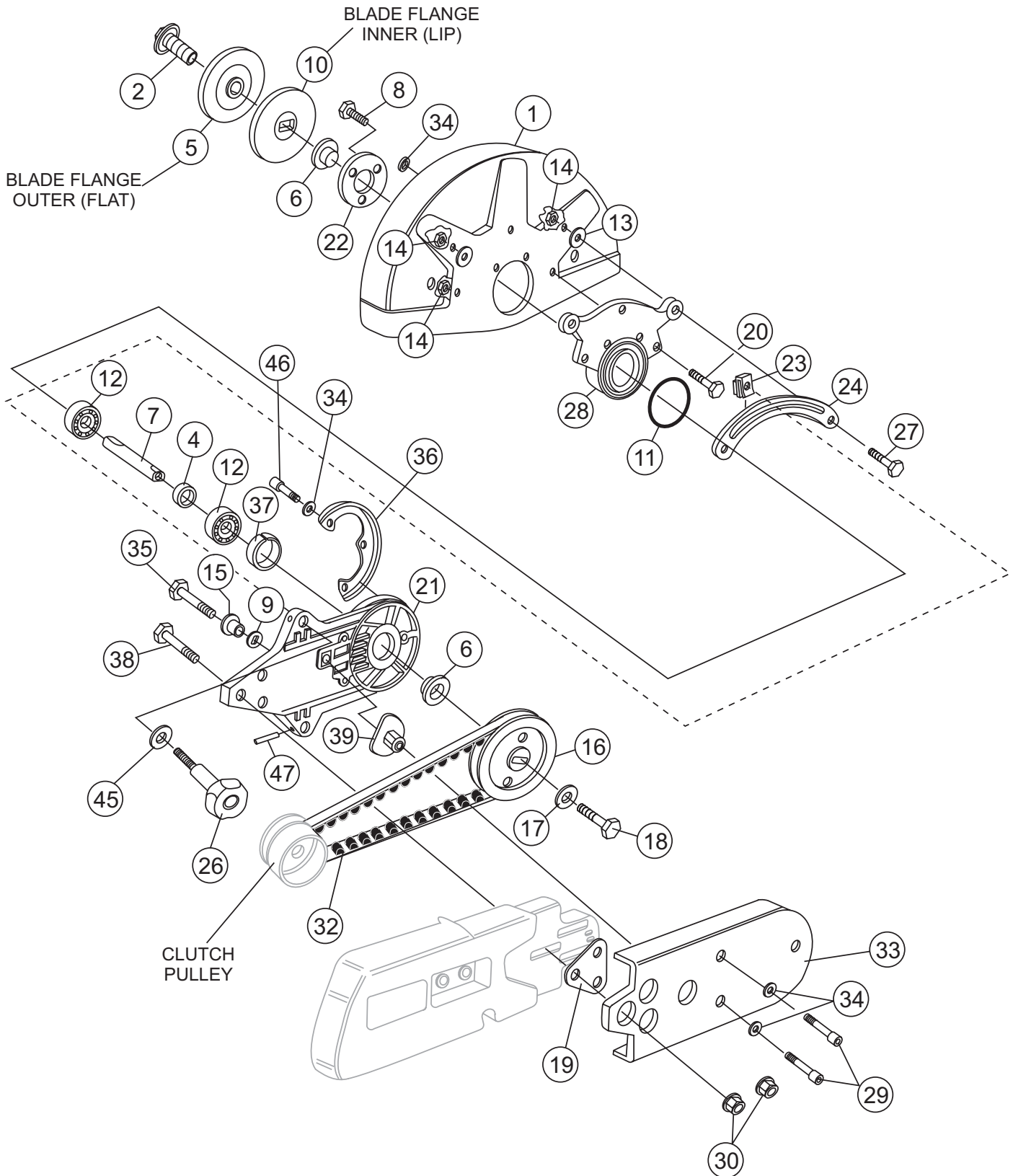

HS62A CUT-OFF SAW — V-BELT COVER (PULLEY) /BLADE GUARD ASSY.

V-BELT COVER (PULLEY-SIDE)/BLADE GUARD ASSY.

<u>NO.</u>	<u>PART NO.</u>	<u>PART NAME</u>	<u>QTY.</u>	<u>REMARKS</u>
1	HS52010026	BLADE COVER 14-INCH	1	
2	HS52010177	SCREW AND WASHER	1	
4	HS52010045	SPACER	1	
5	HS018600235	FLANGE, ARBOR (OUTER)	1	
6	HS52010044	SPACER	2	
7	HS018600019	SHAFT	1	
8	HS3806022	SCREW	3	
9	HS005000343	WASHER	1	
10	HS018600236A	FLANGE, ARBOR (INNER)	1	
11	HS018100029	O-RING, BLADE GUARD SUPPORT	1	
12	HS3035019	BEARING	2	
13	HS093000020	SPACER	1	
14	HS094000251	NUT	5	
15	HS52010039	SPACER	1	
16	HS01860004A	PULLEY, BELT	1	
17	HS3918013	WASHER	1	
18	HS3806065	SCREW	1	
19	HS52010305	PLATE	17	
20	HS3806021	SCREW	5	
21	HS52010212	ARM	1	
22	HS52010043	FLANGE	1	
23	HS52010013	LOCK, GUIDE BLADE GUARD	1	
24	HS52010396	GUIDE, BLADE GUARD	1	
26	HS52010062	KNOB, ADJUSTMENT GUIDE	1	
27	HS3802005A	SCREW	2	
28	HS52010025A	SUPPORT BLADE GUARD	1	
29	HS3801016	SCREW	2	
30	HS3914010	NUT	3	
32	HS52020020	V-BELT	1	
33	HS52010022A	COVER, V-BELT (PULLEY SIDE)	1	
34	HS3833073	WASHER	6	
35	HS3806037A	SCREW	1	
36	HS52010211	GUARD	1	
37	HS52010046	BUSHING	1	
38	HS52010401	SCREW	1	
39	HS52010036	BELT ADJUSTER	1	
45	HS3833080	WASHER	1	
46	HS3906019	SCREW	1	
47	HS52010428	PLASTIC PIN	2	

HS62A CUT-OFF SAW — FUEL TANK ASSY.

FUEL TANK ASSY.

<u>NO.</u>	<u>PART NO.</u>	<u>PART NAME</u>	<u>QTY.</u>	<u>REMARKS</u>
4	HS52010082	BREATHER	1	
5	HS093000448	TUBE	1	
6	HS018500066	FITTING	1	
8	HS018500096	VALVE BODY	1	
9	HS50010093	CLIP	1	
15*	HS099900090	O-RING	1	
16	HS52022005	CAP, FUEL	1	INCLUDES ITEM W/ *
19	HS50010061R	SHOCK ABSORBER	1	
28	HS50010218	FILTER, FUEL	1	
29	HS50010093	TUBE	1	
30	HS50140023	GROMMET	1	

HS62A CUT-OFF SAW — LIFTING HANDLE AND ROLLER ASSY.

LIFTING HANDLE AND ROLLER ASSY.

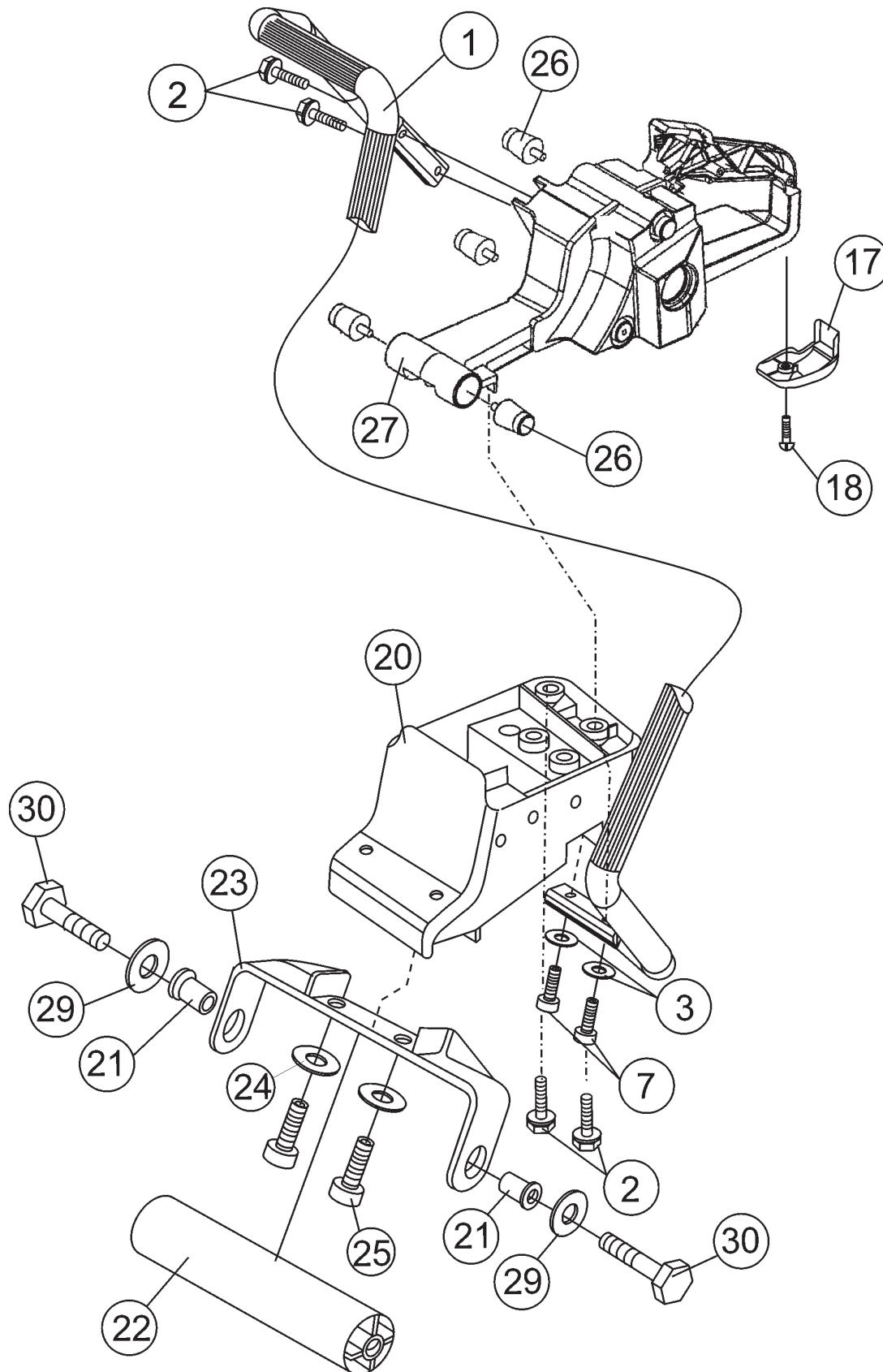

HS62A CUT-OFF SAW — LIFTING HANDLE AND ROLLER ASSY.

LIFTING HANDLE AND ROLLER ASSY.

<u>NO.</u>	<u>PART NO.</u>	<u>PART NAME</u>	<u>QTY.</u>	<u>REMARKS</u>
1	HS52020023	HANDLE	1	
2	HS018100317	SCREW	4	
3	HS3072015	WASHER	2	
7	HS3801020	SCREW	2	
17	HS52020026	GUARD, FUEL TANK	1	
18	HS3960087	SCREW	1	
20	HS52010214	MAIN ROLLER SUPPORT UPPER	1	
21	HS3960045	SPACER, ROLLER SUPPORT LOWER	2	
22	HS018100171A	ROLLER	1	
23	HS52010098	SUPPORT, ROLLER LOWER	1	
25	HS38003035	SCREW	2	
26	HS52010066R	SHOCK ABSORBER	4	
27	HS52020077A	FUEL TANK ASSY.	1	
29	HS3833076	WASHER	4	
30	HS3806035	SCREW	2	

HS62A CUT-OFF SAW — THROTTLE LINKAGE ASSY.

THROTTLE ASSY.

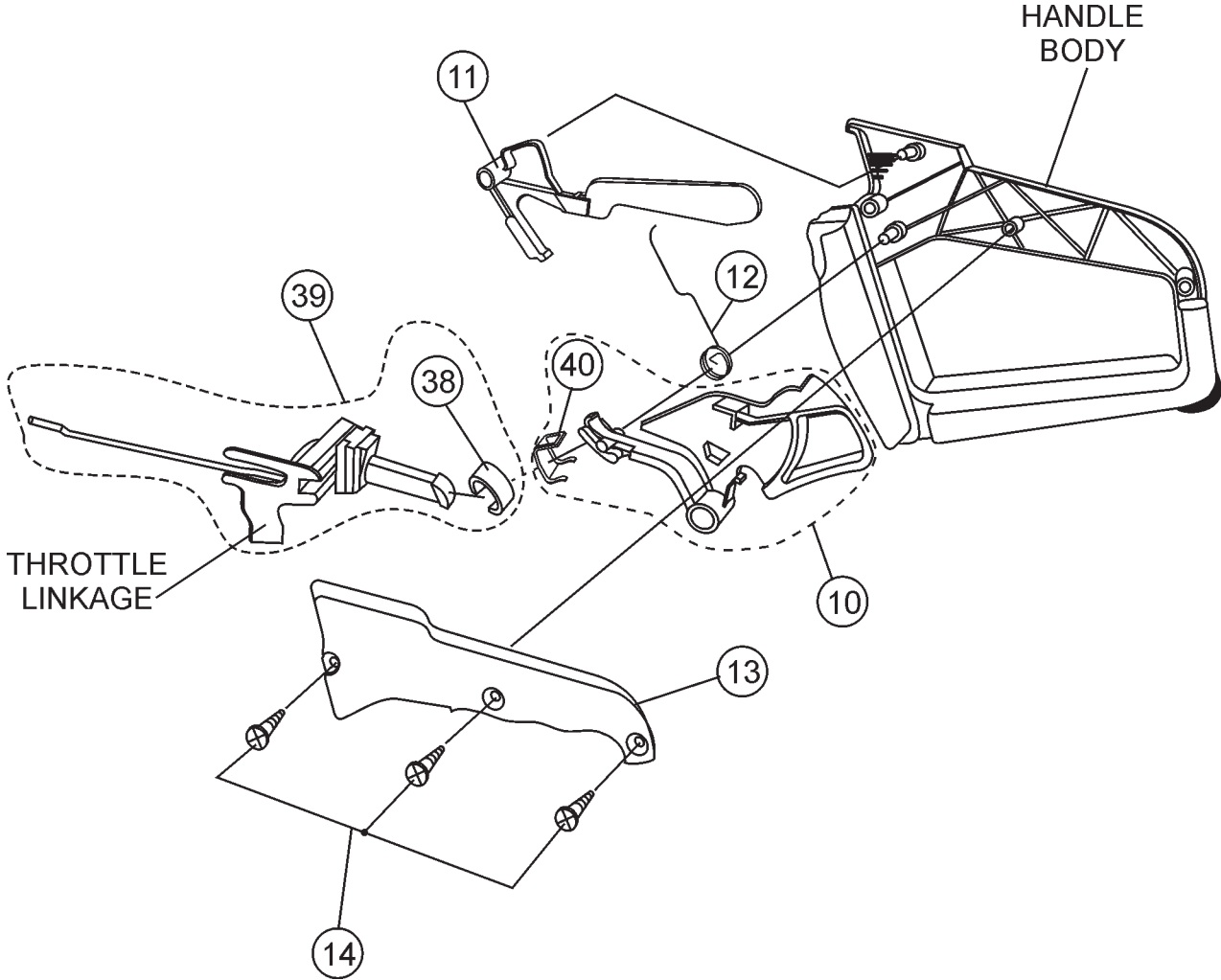

HS62A CUT-OFF SAW — THROTTLE LINKAGE ASSY.

THROTTLE ASSY

<u>NO.</u>	<u>PART NO.</u>	<u>PART NAME</u>	<u>QTY.</u>	<u>REMARKS</u>
10	HS52010092	THROTTLE TRIGGER LEVER	1	INCLUDES ITEM W/ #
11	HS52010077	THROTTLE LOCK LEVER	1	
12	HS097000028	SPRING	1	
13	HS097000024	COVER, HANDLE/TANK	1	
14	HS3960040	SCREW	3	
38%		CAP, THROTTLE LINKAGE	1	NOT SOLD SEPARATELY
39	HS52022048A	THROTTLE LINKAGE	1	INCLUDES ITEM W/ %
40#		PLATE	1	NOT SOLD SEPARATELY

HS62A CUT-OFF SAW — FLYWHEEL COVER ASSY.

FLYWHEEL COVER ASSY.

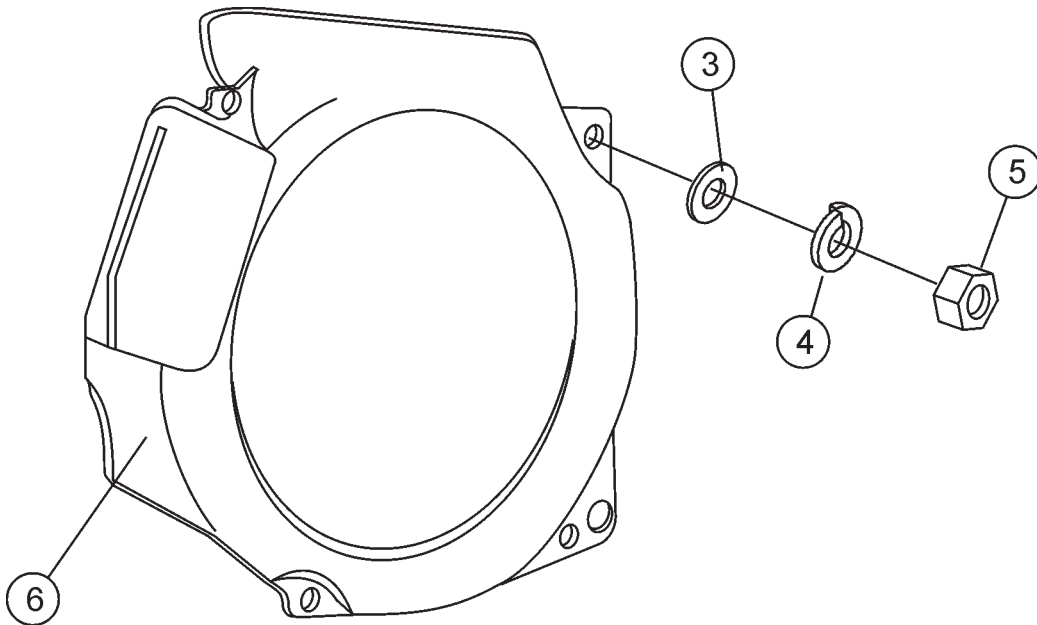

HS62A CUT-OFF SAW — FLYWHEEL COVER ASSY.

FLYWHEEL COVER ASSY.

<u>NO.</u>	<u>PART NO.</u>	<u>PART NAME</u>	<u>QTY.</u>	<u>REMARKS</u>
3	HS005000361	WASHER, FLAT	1	
4	HS3833080	WASHER, LOCK	1	
5	HS004000142	NUT	1	
6	HS500110019A	FLANGE, STARTER	1	

HS62A CUT-OFF SAW — FLYWHEEL ASSY.

FLYWHEEL ASSY.

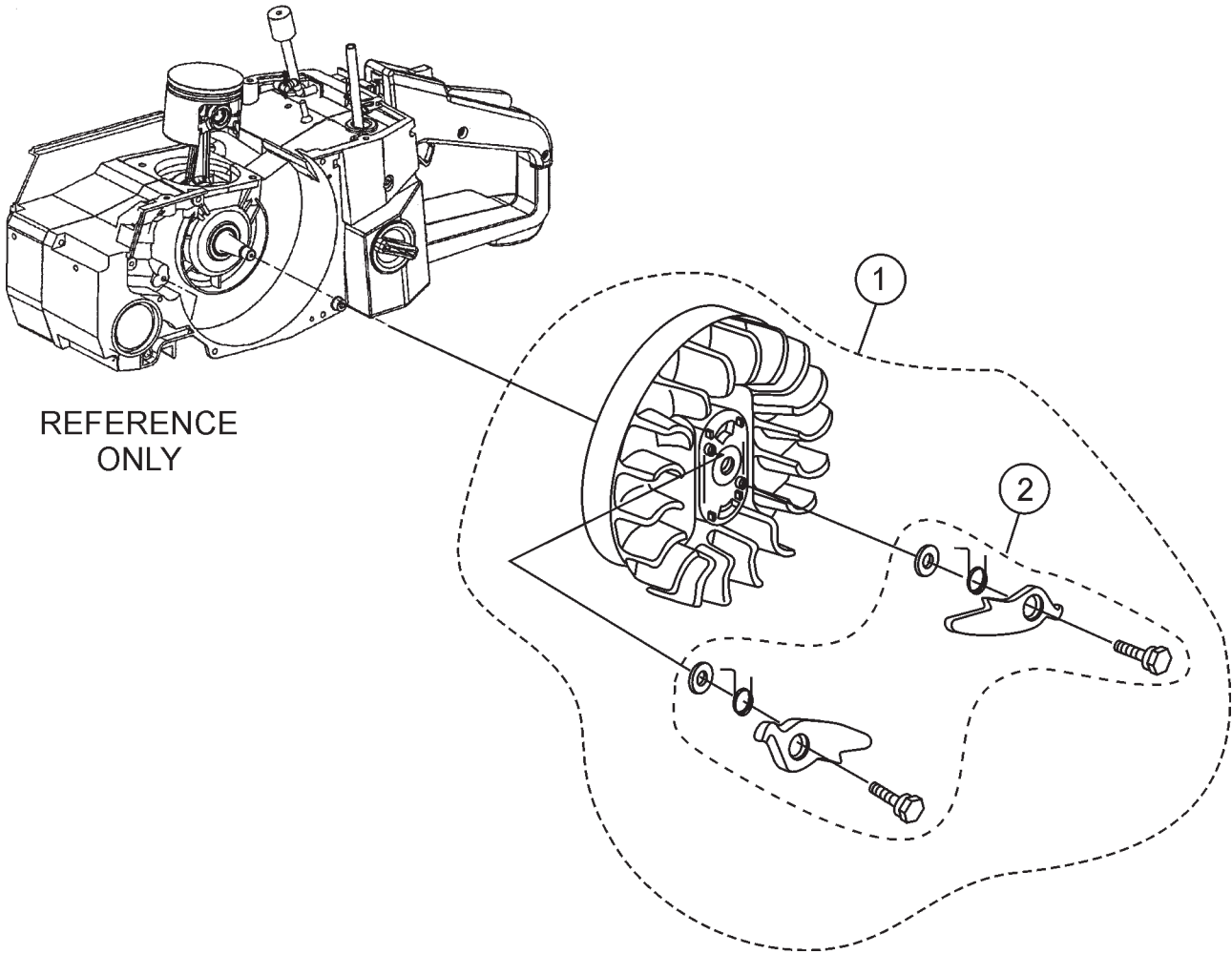

HS62A CUT-OFF SAW — FLYWHEEL ASSY.

FLYWHEEL ASSY.

<u>NO.</u>	<u>PART NO.</u>	<u>PART NAME</u>	<u>QTY.</u>	<u>REMARKS</u>
1	HS52020247R	FLYWHEEL	1	INCLUDES ITEM W/*
2*	HS52012027	PAWL SET	1	

HS62A CUT-OFF SAW — IGNITION COIL ASSY.

IGNITION COIL ASSY.

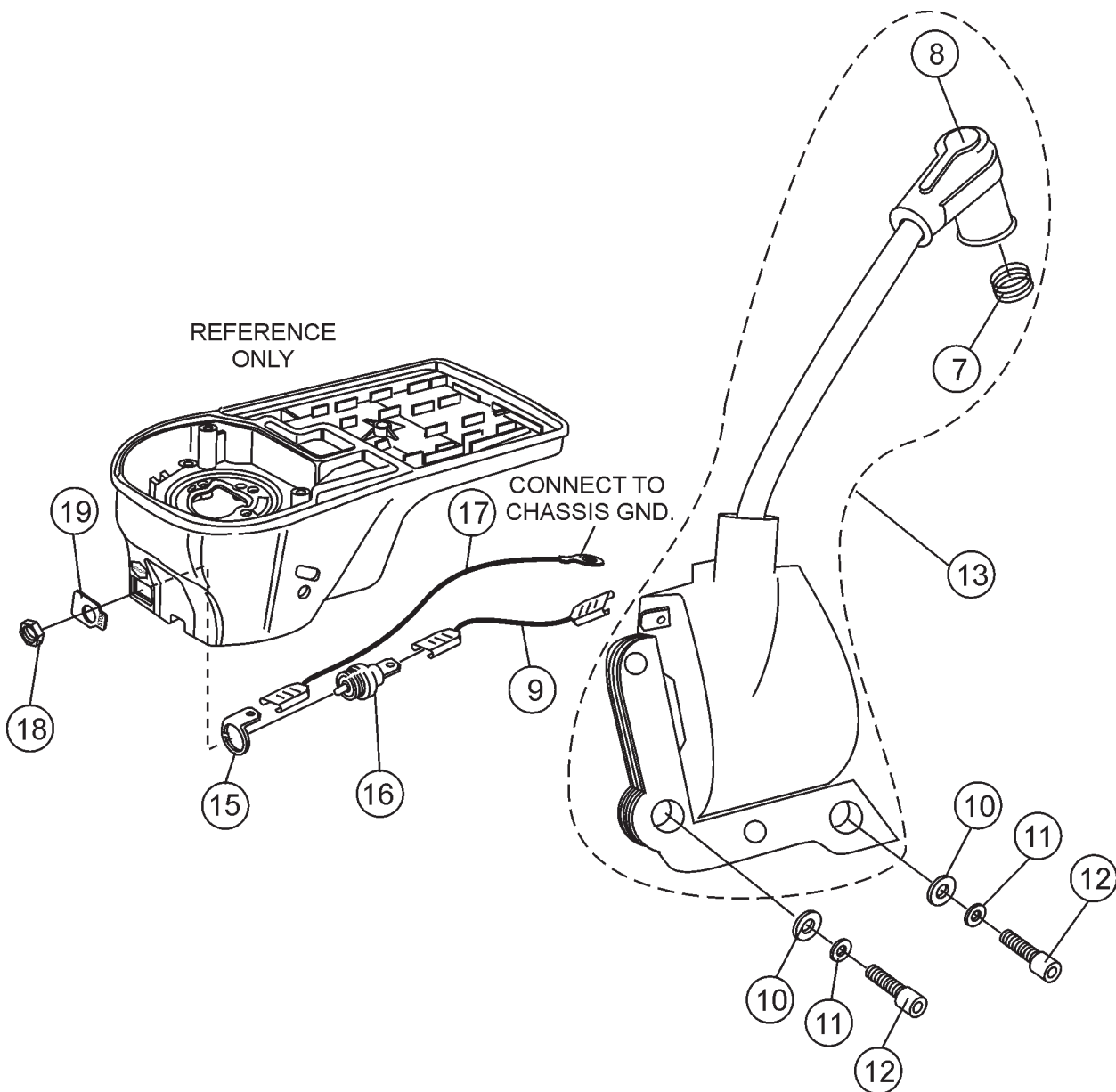

HS62A CUT-OFF SAW — IGNITION COIL ASSY.

IGNITION COIL ASSY.

<u>NO.</u>	<u>PART NO.</u>	<u>PART NAME</u>	<u>QTY.</u>	<u>REMARKS</u>
7*	HS094600169	SPRING SPARK PLUG	1	
8*	HS094600097A	CAP, SPARK PLUG	1	
9	HS052010362	CABLE WIRE	1	
10	HS3916004	WASHER	2	
11	HS006000315	WASHER	2	
12	HS094000227	SCREW	2	
13	HS52020148R	COIL, IGNITION ASSY.	1	INCLUDES ITEMS W/*
15	HS52010132	CONNECTING LINK	1	
16	HS094500497	SWITCH, ON-OFF	1	
17	HS097000121A	CABLE WIRE, ON-OFF SWITCH	1	
18	HS099900397	NUT	1	
19	HS004000438	PLATE, ON-OFF SWITCH	1	

HS62A CUT-OFF SAW — AIR FILTER ASSY.

AIR FILTER ASSY.

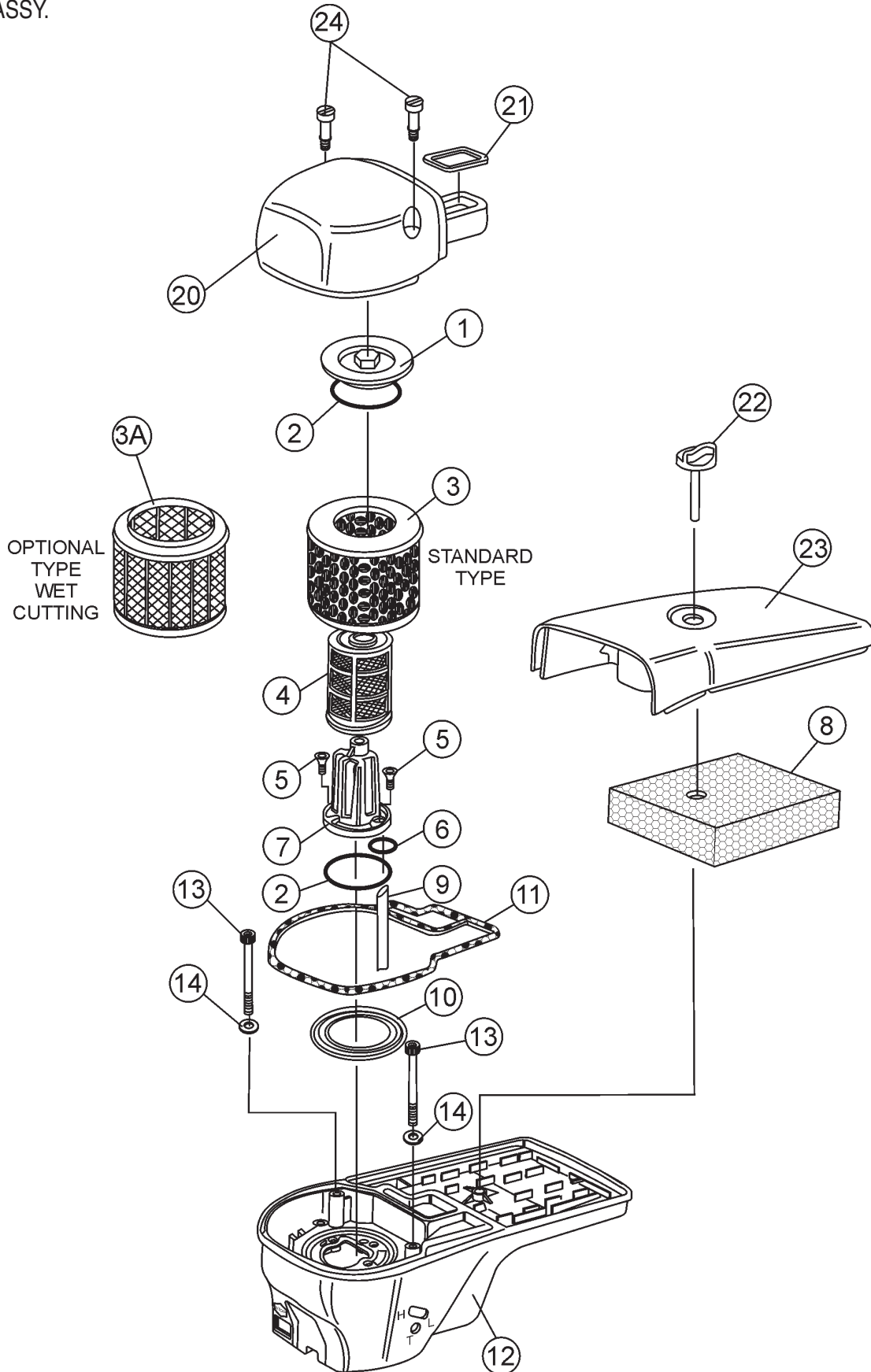

HS62A CUT-OFF SAW — AIR FILTER ASSY.

AIR FILTER ASSY.

<u>NO.</u>	<u>PART NO.</u>	<u>PART NAME</u>	<u>QTY.</u>	<u>REMARKS</u>
1	HS52012024B	FLANGE, PRE- FILTER, CAP	1	
2	HS330000010	O- RING, FLANGE PRE- FILTER	2	
3	HS018600125R	FILTER, AIR (STANDARD)	1	
3A	HS099900778A	FILTER, AIR (WET CUTTING)	1 OPTIONAL
4	HS018600056AR	FILTER, AIR INNER	1	
5	HS3802002A	SCREW, FILTER SUPPORT	3	
6	HS3049007	O-RING	1	
7	HS52010014B	SUPPORT, FILTER	1	
8	HS52020270R	PRE- FILTER, FOAM	1	
9	HS093000468A	SCREW	1	
10	HS018600090A	GASKET, AIR FILTER LOWER	1	
11	HS52020021	GASKET, AIR FILTER BASE	1	
12	HS52010016	COVER, AIR FILTER LOWER	1	
13	HS072700182	SCREW, AIR CLEANER MTG.	3	
14	HS3833073	WASHER, AIR CLEANER MTG.	3	
20	HS52022006	COVER, AIR FILTER, UPPER	1	
21	HS52010060	GASKET, AIR FILTER COVER	1	
22	HS52010041	KNOB, AIR FILTER COVER	1	
23	HS52020018	COVER, AIR FILTER, LONG	1	
24	HS093000468A	SCREW, AIR FILTER COVER	2	

HS62A CUT-OFF SAW — CARBURETOR MOUNTING ASSY.

CARBURETOR MOUNTING ASSY.

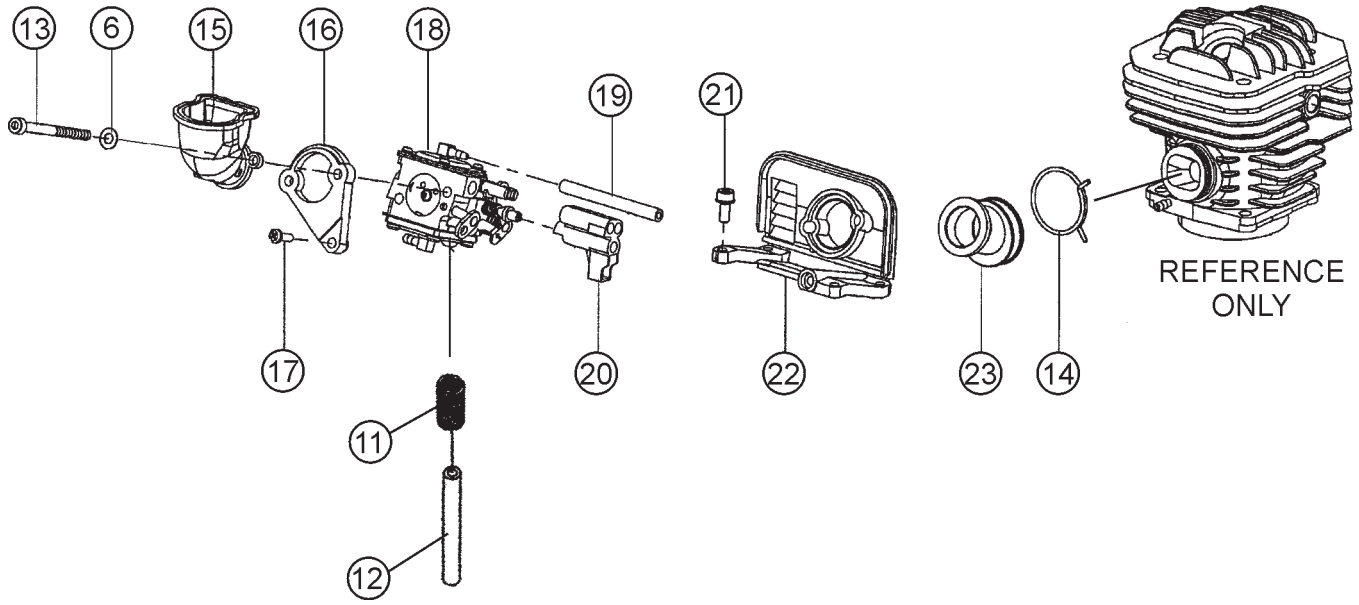

HS62A CUT-OFF SAW — CARBURETOR MOUNTING ASSY.

CARBURETOR MOUNTING ASSY.

<u>NO.</u>	<u>PART NO.</u>	<u>PART NAME</u>	<u>QTY.</u>	<u>REMARKS</u>
6	HS3833073	WASHER	2	
11	HS52020060	SPRING	1	
12	HS094000215A	TUBE	1	
13	HS61052009B	SCREW	1	
14	HS097000059A	SPRING, MANIFOLD	1	
15	HS52020008B	MANIFOLD, OUTER	1	
16	HS50010028	FLANGE	1	
17	HS3960057	SCREW	1	
18	HS52020271	CARBURETOR ASSEMBLY	1	
19	HS018100354	FUEL LINE, CARBURETOR	1	
20	HS52020177	SCREW	1	
21	HS097000092A	SCREW	1	
22	HS52020039	SUPPORT, CARBURETOR	1	
23	HS50020026	MANIFOLD, INNER	1	

HS62A CUT-OFF SAW — CARBURETOR ASSY.

CARBURETOR ASSY.

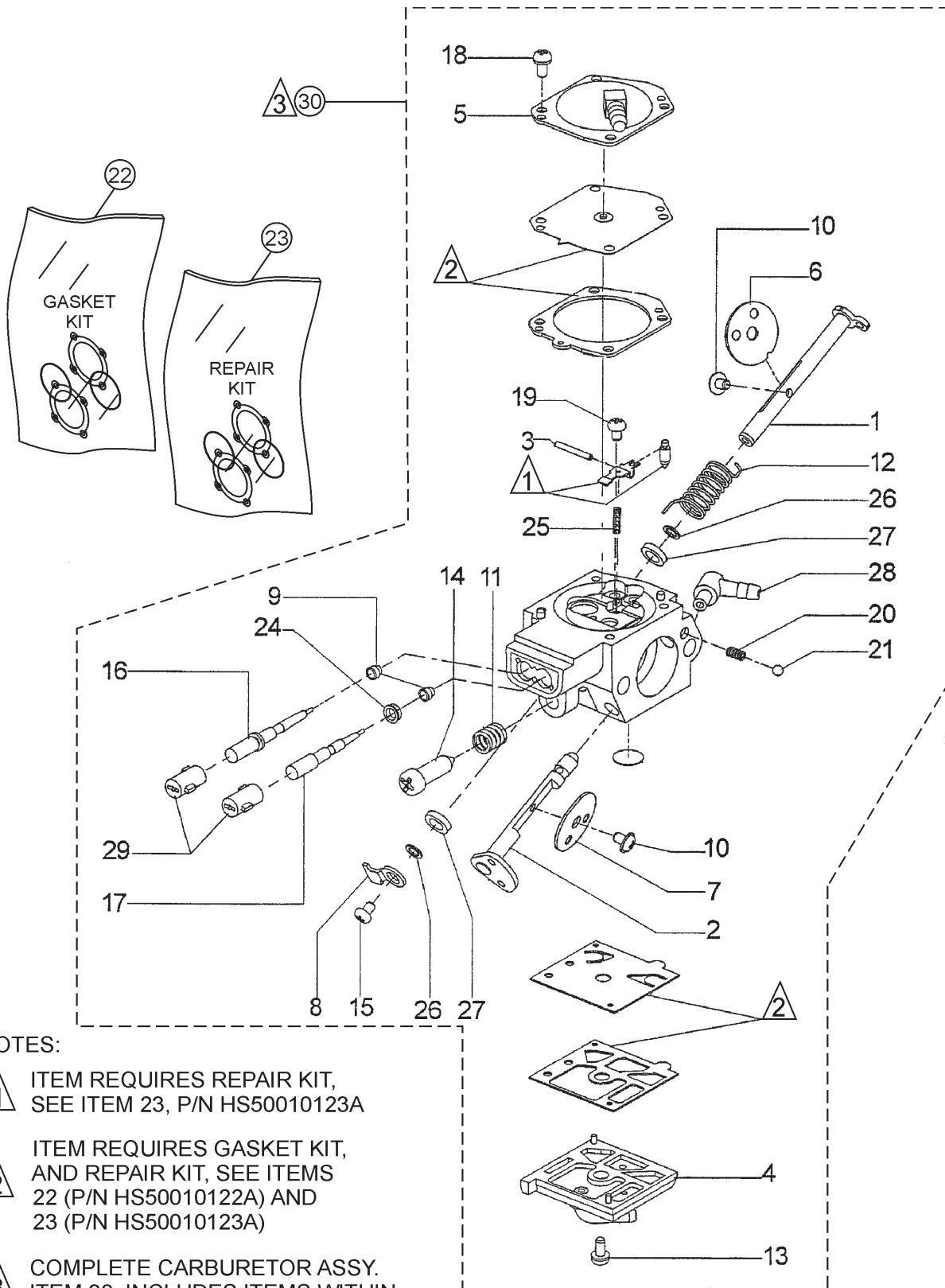

NOTES:

- 1** ITEM REQUIRES REPAIR KIT, SEE ITEM 23, P/N HS50010123A
- 2** ITEM REQUIRES GASKET KIT, AND REPAIR KIT, SEE ITEMS 22 (P/N HS50010122A) AND 23 (P/N HS50010123A)
- 3** COMPLETE CARBURETOR ASSY. ITEM 30, INCLUDES ITEMS WITHIN DASHED LINES.

HS62A CUT-OFF SAW — CARBURETOR ASSY.

CARBURETOR ASSY.

<u>NO.</u>	<u>PART NO.</u>	<u>PART NAME</u>	<u>QTY.</u>	<u>REMARKS</u>
1*	HS50010095	THROTTLE SHAFT	1	
2*	HS50010096	STARTER SHAFT	1	
3*	HS00300201	SPINDLE	1	
4*	HS52020080	COVER, TOP	1	
5*	HS52020081	COVER, BOTTOM	1	
6*	HS50010099	SHUTTER	1	
7*	HS50010100	SHUTTER	1	
8*	HS2318839	CLAMP	1	
9*	HS2318634	CAP	2	
10*	HS380000338	SCREW	1	
11*	HS094600148	SPRING	2	
12*	HS50010106	SPRING	1	
13*	HS50010109	SCREW	1	
14*	HS074000240	ADJUST SCREW	1	
15*	HS003300209	SCREW	1	
16*	HS2318837	SCREW "L" CARBURETOR	1	
17*	HS2318838	SCREW "H" CARBURETOR	1	
18*	HS035000162	SCREW	4	
19*	HS003300202	SCREW	1	
20*	HS095000146	SPRING	1	
21*	HS094600143	BALL	1	
22	HS50010122A	KIT, GASKET CARBURETOR	1	
23	HS50010123A	KIT, REPAIR CARBURETOR	1	
24*	HS2318632	SUPPORT	1	
25*	HS50010105	SPRING	1	
26*	HS015400153	WASHER	2	
27*	HS380000272	SEAL RING	2	
28*	HS003300036	FITTING	1	
29*	HS2318867	CLAMP	2	
30	HS52020271	CARBURETOR ASSY., HDA225	1	INCLUDES ITEMS W/*

HS62A CUT-OFF SAW — CRANKSHAFT / PISTON ASSY.

CRANKSHAFT AND PISTON ASSY.

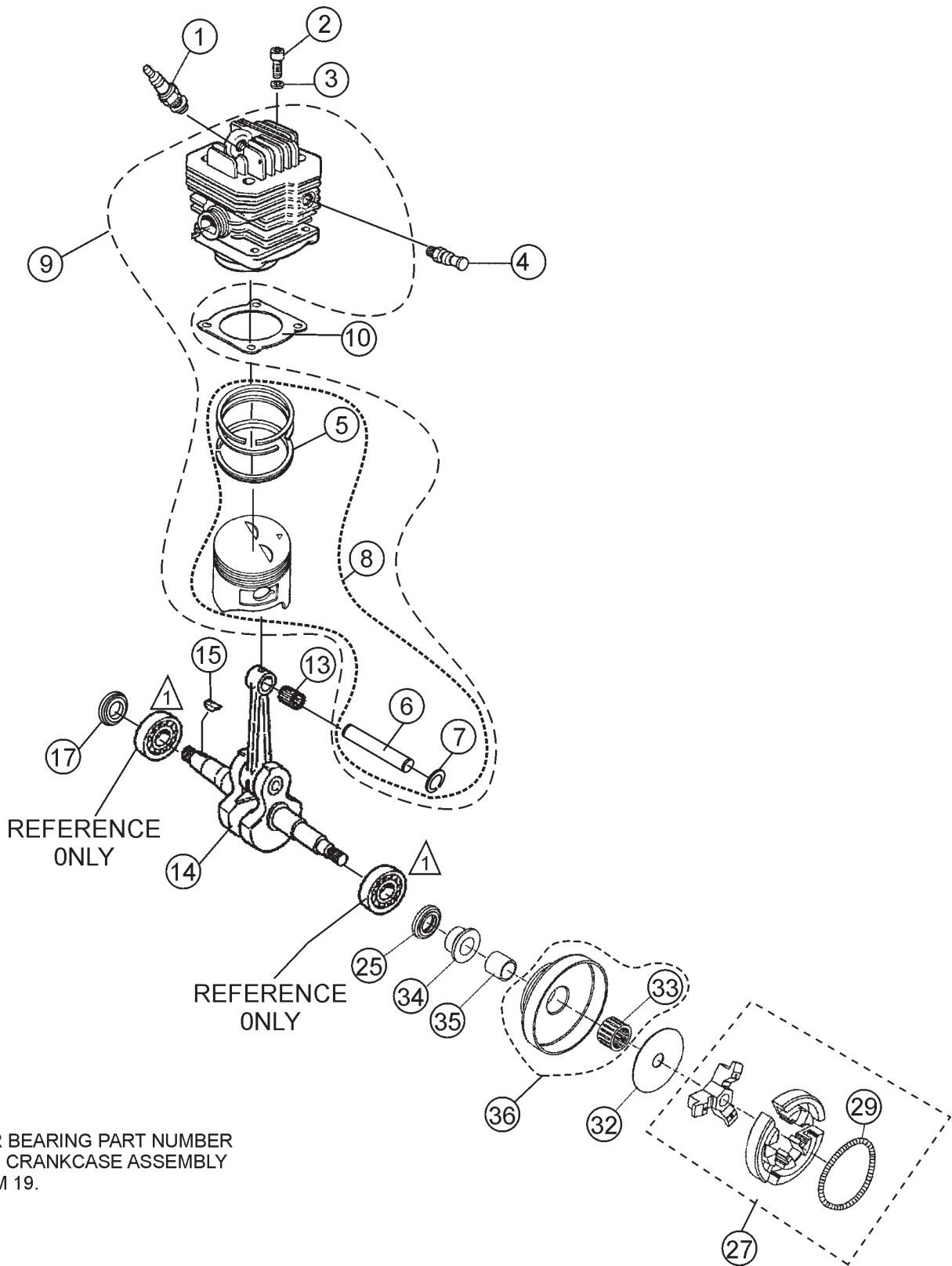

NOTES:

- △ FOR BEARING PART NUMBER
SEE CRANKCASE ASSEMBLY
ITEM 19.

HS62A CUT-OFF SAW — CRANKSHAFT AND PISTON ASSY.

CRANKSHAFT AND PISTON ASSY.



<u>NO.</u>	<u>PART NO.</u>	<u>PART NAME</u>	<u>QTY.</u>	<u>REMARKS</u>
1	HS3055118	SPARK PLUG	1	
2	HS005100906A	SCREW	4	
3	HS3833076	WASHER	4	
4	HS50010215	DECOMPRESSOR	1	
5*#	HS50020004	PISTON RINGS	1	
6*#	HS50010031	PISTON PIN	1	
7*#	HS007201198	RING, PISTON PIN	2	
8*	HS50092013	PISTON ASSEMBLY W /RINGS	1	INCLUDES ITEMS W /#
9	HS50092028	CYLINDER ASSEMBLY W /PISTON	1	INCLUDES ITEMS W /*
10	HS50010046B	GASKET, CYLINDER	1	
13	HS3037014	BEARING, UPPER CRANKSHAFT	1	
14	HS50090001R	CRANKSHAFT	1	
15	HS094500028R	KEY, CRANKSHAFT	1	
17	HS094500004	SEAL RING	1	
25	HS007201313	SEAL RING, CRANKSHAFT	1	
27	HS50012023AR	CLUTCH ASSEMBLY	1	INCLUDES ITEMS W /+
29+	HS004900137B	SPRING, CLUTCH	1	
32	HS097000097	WASHER	1	
33\$	HS52010030	BEARING	1	
34	HS52010035	SPACER, CLUTCH DRUM	1	
35	HS52010034	BUSHING, CLUTCH DRUM	1	
36	HS52010029R	CLUTCH DRUM	1	INCLUDES ITEMS W /\$

HS62A CUT-OFF SAW — WATER KIT ASSY.

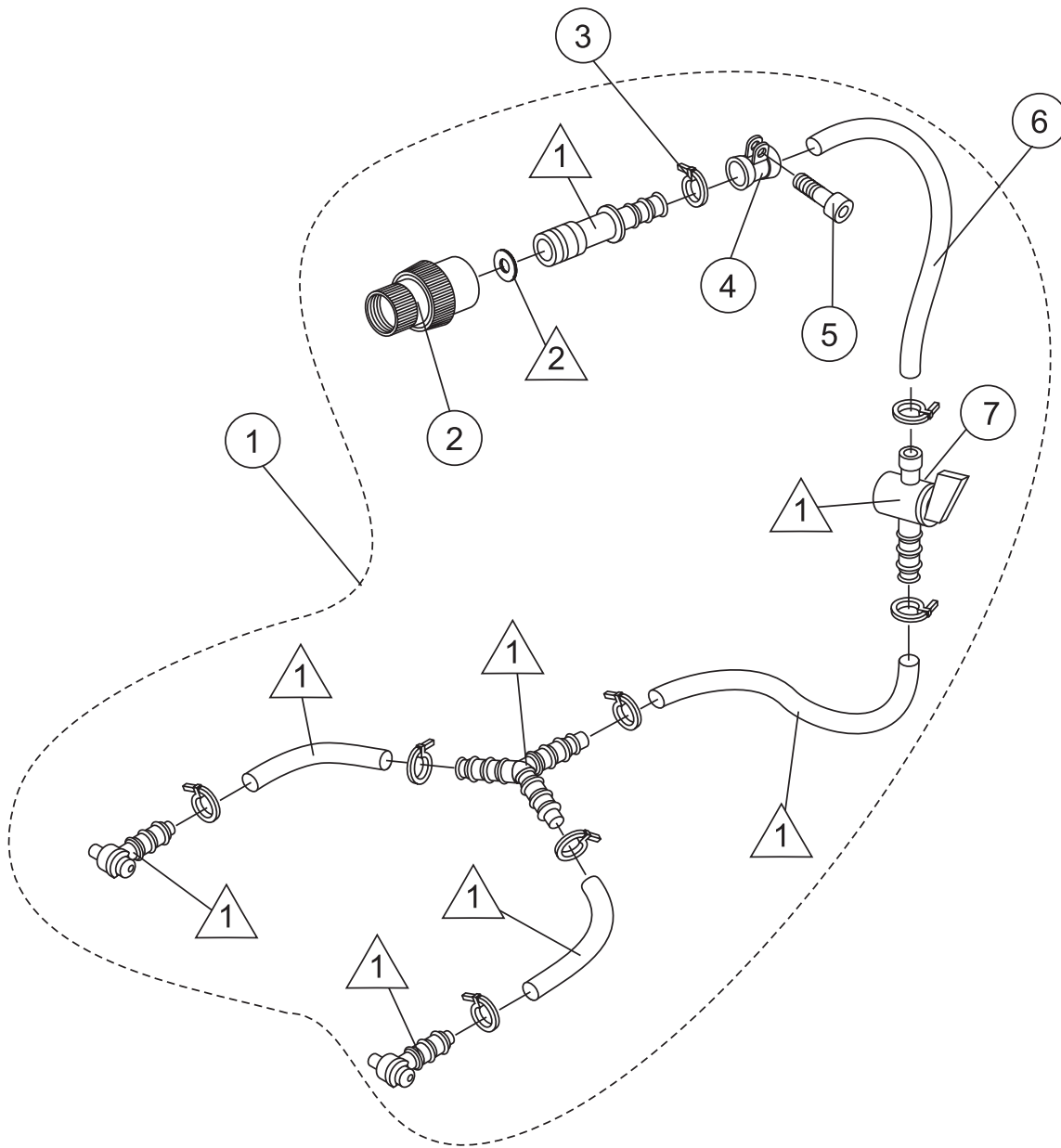
WATER KIT ASSY.



NOTES:

-  INCLUDED WITH WATER HOSE, ITEM 6
-  INCLUDED WITH SOCKET HEAD CAP SCREW, ITEM 5

HS62A CUT-OFF SAW — WATER KIT ASSY.

WATER KIT ASSY.

<u>NO.</u>	<u>PART NO.</u>	<u>PART NAME</u>	<u>QTY.</u>	<u>REMARKS</u>
1	HS52012062	WATER KIT ASSY.	1	INCLUDES ITEMS W/*
2*	HS52010121	FITTING, QUICK DISCONNECT	1	
3*		PLASTIC TIE WRAPS	8	NOT SOLD SEPARATELY
4*		HOSE CLAMP	1	NOT SOLD SEPARATELY
5*		SCREW, SOCKET HEAD CAP W/WASHER	1	NOT SOLD SEPARATELY
6*		HOSE, WATER	1	NOT SOLD SEPARATELY
7*	HS52010207	VALVE, SHUT-OFF	1	

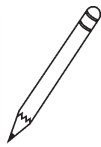

Items 3-6 are included with the Water Kit Assembly and cannot be purchased separately.

TOOLS

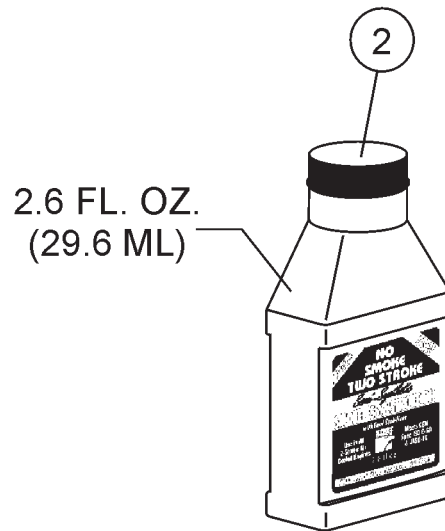
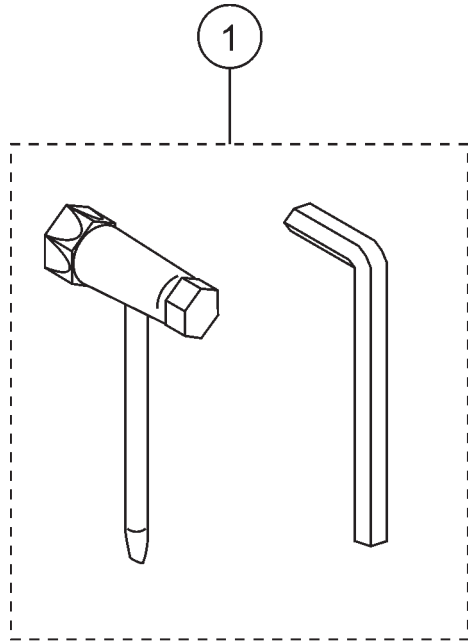

CANNOT BE PURCHASED
SEPARATELY, MUST ORDER
A CASE OF 36.

HS62A CUT-OFF SAW — TOOLS

TOOLS

<u>NO.</u>	<u>PART NO.</u>	<u>PART NAME</u>	<u>QTY.</u>	<u>REMARKS</u>
1	HS4191240	TOOL KIT	1	
2	00325	SMOKELESS 2-STROKE OIL.....	1	CAN ONLY BE PURCHASED AS A CASE (QTY 36)

HS62A CUT-OFF SAW — RECOMMENDED DIAMOND BLADES

Recommended Diamond Blades for Your *Side Winder* Saw

Blade Type	Asphalt	Green Concrete	Light Weight Block	Concrete Block	Cured Concrete	Standard Red Brick	Concrete (Brick) Pavers	Soft Stone	Medium Stone	Hard Stone
GES				GES						
GPS				GPS						
GPSA	GPSA									
SBL				SBL						
SBLA	SBLA									
PDHS1				PDHS1						
PDHS1A	PDHS1A									
PDHS2				PDHS2						
PDHS2A	PDHS2A									
SW2				SW2						
SW2G	SW2G			SW2						
PDHS3				PDHS3						
PDHS3A	PDHS3A									
SDW				SDW						
SWG	SWG									
HSC				HSC						
HSG							HSG			
PVL				PVL						
KBL					KBL					
BBL		BBL								
GET				GET						
GPT					GPT					
TBL					TBL					

PAYMENT TERMS

Terms of payment for parts are net 30 days.

FREIGHT POLICY

All parts orders will be shipped collect or prepaid with the charges added to the invoice. All shipments are F.O.B. point of origin. Multiquip's responsibility ceases when a signed manifest has been obtained from the carrier, and any claim for shortage or damage must be settled between the consignee and the carrier.

MINIMUM ORDER

The minimum charge for orders from Multiquip is \$15.00 net. Customers will be asked for instructions regarding handling of orders not meeting this requirement.

RETURNED GOODS POLICY

Return shipments will be accepted and credit will be allowed, subject to the following provisions:

1. A Returned Material Authorization must be approved by Multiquip prior to shipment.
2. To obtain a Return Material Authorization, a list must be provided to Multiquip Parts Sales that defines item numbers, quantities, and descriptions of the items to be returned.
 - a. The parts numbers and descriptions must match the current parts price list.
 - b. The list must be typed or computer generated.
 - c. The list must state the reason(s) for the return.
 - d. The list must reference the sales order(s) or invoice(s) under which the items were originally purchased.
 - e. The list must include the name and phone number of the person requesting the RMA.
3. A copy of the Return Material Authorization must accompany the return shipment.
4. Freight is at the sender's expense. All parts must be returned freight prepaid to Multiquip's designated receiving point.

5. Parts must be in new and resalable condition, in the original Multiquip package (if any), and with Multiquip part numbers clearly marked.
6. The following items are not returnable:
 - a. Obsolete parts. (If an item is in the price book and shows as being replaced by another item, it is obsolete.)
 - b. Any parts with a limited shelf life (such as gaskets, seals, "O" rings, and other rubber parts) that were purchased more than six months prior to the return date.
 - c. Any line item with an extended dealer net price of less than \$5.00.
 - d. Special order items.
 - e. Electrical components.
 - f. Paint, chemicals, and lubricants.
 - g. Decals and paper products.
 - h. Items purchased in kits.
7. The sender will be notified of any material received that is not acceptable.
8. Such material will be held for five working days from notification, pending instructions. If a reply is not received within five days, the material will be returned to the sender at his expense.
9. Credit on returned parts will be issued at dealer net price at time of the original purchase, less a 15% restocking charge.
10. In cases where an item is accepted, for which the original purchase document can not be determined, the price will be based on the list price that was effective twelve months prior to the RMA date.
11. Credit issued will be applied to future purchases only.

PRICING AND REBATES

Prices are subject to change without prior notice. Price changes are effective on a specific date and all orders received on or after that date will be billed at the revised price. Rebates for price declines and added charges for price increases will not be made for stock on hand at the time of any price change.

Multiquip reserves the right to quote and sell direct to Government agencies, and to Original Equipment Manufacturer accounts who use our products as integral parts of their own products.

SPECIAL EXPEDITING SERVICE

A \$35.00 surcharge will be added to the invoice for special handling including bus shipments, insured parcel post or in cases where Multiquip must personally deliver the parts to the carrier.

LIMITATIONS OF SELLER'S LIABILITY

Multiquip shall not be liable hereunder for damages in excess of the purchase price of the item with respect to which damages are claimed, and in no event shall Multiquip be liable for loss of profit or good will or for any other special, consequential or incidental damages.

LIMITATION OF WARRANTIES

No warranties, express or implied, are made in connection with the sale of parts or trade accessories nor as to any engine not manufactured by Multiquip. Such warranties made in connection with the sale of new, complete units are made exclusively by a statement of warranty packaged with such units, and Multiquip neither assumes nor authorizes any person to assume for it any other obligation or liability whatever in connection with the sale of its products. Apart from such written statement of warranty, there are no warranties, express, implied or statutory, which extend beyond the description of the products on the face hereof.

OPERATION & PARTS MANUAL

HERE'S HOW TO GET HELP

PLEASE HAVE THE MODEL AND SERIAL
NUMBER *ON-HAND* WHEN CALLING

UNITED STATES

Multiquip Corporate Office

18910 Wilmington Ave. Tel. (800) 421-1244
Carson, CA 90746 Fax (800) 537-3927
Contact: mq@multiquip.com

Mayco Parts

800-306-2926 Fax: 800-672-7877
310-537-3700 Fax: 310-637-3284

Service Department

800-421-1244 Fax: 310-537-4259
310-537-3700

MQ Parts Department

800-427-1244 Fax: 800-672-7877
310-537-3700 Fax: 310-637-3284

Warranty Department

800-421-1244, Ext. 279 Fax: 310-537-1173
310-537-3700, Ext. 279

Technical Assistance

800-478-1244 Fax: 310-631-5032

MEXICO

MQ Cipsa

Carr. Fed. Mexico-Puebla KM 126.5 Tel: (52) 222-225-9900
Momoxpan, Cholula, Puebla 72760 Mexico Fax: (52) 222-285-0420
Contact: pmastretta@cipsa.com.mx

CANADA

Multiquip

4110 Industriel Boul. Tel: (450) 625-2244
Laval, Quebec, Canada H7L 6V3 Fax: (450) 625-8664
Contact: jmartin@multiquip.com

UNITED KINGDOM

Multiquip (UK) Limited Head Office

Hanover Mill, Fitzroy Street, Tel: 0161 339 2223
Ashton-under-Lyne, Fax: 0161 339 3226
Lancashire OL7 0TL
Contact: sales@multiquip.co.uk

BRAZIL

Multiquip

Av. Evandro Lins e Silva, 840 - grupo 505 Tel: 011-55-21-3433-9055
Barra de Tijuca - Rio de Janeiro Fax: 011-55-21-3433-9055
Contact: cnavarro@multiquip.com.br, srentes@multiquip.com.br

© COPYRIGHT 2006, MULTIQUIP INC.

Multiquip Inc. and the MQ logo are registered trademarks of Multiquip Inc. and may not be used, reproduced, or altered without written permission. All other trademarks are the property of their respective owners and used with permission.

This manual MUST accompany the equipment at all times. This manual is considered a permanent part of the equipment and should remain with the unit if resold.

The information and specifications included in this publication were in effect at the time of approval for printing. Illustrations are based on the *HS62A Cut-Off Saw*. Illustrations, descriptions, references and technical data contained in this manual are for guidance only and may not be considered as binding. Multiquip Inc. reserves the right to discontinue or change specifications, design or the information published in this publication at any time without notice and without incurring any obligations.

Your Local Dealer is:

